

2021 Online Physics Olympiad: Open Contest (Version 1.1)

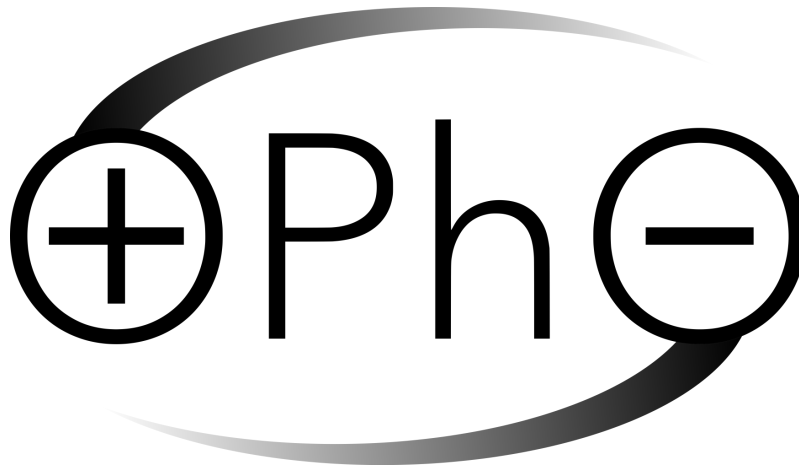

Organizers and Writers: Adithya Balachandran, Rohan Bhowmik, Eddie Chen, Ronald Dobos, Ashmit Dutta, Ethan Hu, Viraj Jayam, Evan Kim, Jacob Nie, Rishab Parthasarathy, Kushal Thaman, Max Wang, QiLin Xue, Leo Yao

Website Developer: Ben Oommen

Sponsors

This competition could not be possible without the help of our sponsors, who are all doing great things in physics, math, and education. Please go check them out!



Jane Street



Wolfram
Language™



AwesomeMath
making x, y, z as easy as a, b, c



Instructions

If you wish to request a clarification, please use [this form](#). To see all clarifications, see [this document](#).

- Use $g = 9.81 \text{ m/s}^2$ in this contest. See the constants sheet on the following page for other constants.
- This test contains 35 short answer questions. Each problem will have three possible attempts.
- The weight of each question depends on our scoring system found [here](#). Put simply, the later questions are worth more, and the overall amount of points from a certain question decreases with the number of attempts that you take to solve a problem as well as the number of teams who solve it. **Note:** Unlike last year, the time it takes will no longer be a factor.
- Any team member is able to submit an attempt. Choosing to split up the work or doing each problem together is up to you. Note that after you have submitted an attempt, your teammates must refresh their page before they are able to see it.
- Answers should contain **three** significant figures, unless otherwise specified. All answers within the 1% range will be accepted.
- When submitting a response using scientific notation, please use exponential form. In other words, if your answer to a problem is $A \times 10^B$, please type AeB into the submission portal.
- A standard scientific or graphing handheld calculator *may* be used. Technology and computer algebra systems like Wolfram Alpha or the one in the TI nSpire will not be needed or allowed. Attempts to use these tools will be classified as cheating.
- You are *allowed* to use Wikipedia or books in this exam. Asking for help on online forums or your teachers will be considered cheating and may result in a possible ban from future competitions.
- Top scorers from this contest will qualify to compete in the Online Physics Olympiad *Invitational Contest*, which is an olympiad-style exam. More information will be provided to invitational qualifiers after the end of the *Open Contest*.
- In general, answer in SI units (meter, second, kilogram, watt, etc.) unless otherwise specified. Please input all angles in degrees unless otherwise specified.
- If the question asks to give your answer as a percent and your answer comes out to be “ $x\%$ ”, please input the value x into the submission form.
- Do not put units in your answer on the submission portal! If your answer is “ x meters”, input only the value x into the submission portal.
- **Do not communicate information to anyone else apart from your team-members before the exam ends on June 6, 2021 at 11:59 PM UTC.**

List of Constants

- Proton mass, $m_p = 1.67 \cdot 10^{-27}$ kg
- Neutron mass, $m_n = 1.67 \cdot 10^{-27}$ kg
- Electron mass, $m_e = 9.11 \cdot 10^{-31}$ kg
- Avogadro's constant, $N_0 = 6.02 \cdot 10^{23}$ mol⁻¹
- Universal gas constant, $R = 8.31$ J/(mol · K)
- Boltzmann's constant, $k_B = 1.38 \cdot 10^{-23}$ J/K
- Electron charge magnitude, $e = 1.60 \cdot 10^{-19}$
- 1 electron volt, $1 \text{ eV} = 1.60 \cdot 10^{-19}$ J
- Speed of light, $c = 3.00 \cdot 10^8$ m/s
- Universal Gravitational constant,

$$G = 6.67 \cdot 10^{-11} \text{ (N} \cdot \text{m}^2\text{)/kg}^2$$

- Acceleration due to gravity, $g = 9.81$ m/s²
- 1 unified atomic mass unit,

$$1 \text{ u} = 1.66 \cdot 10^{-27} \text{ kg} = 931 \text{ MeV}/c^2$$

- Planck's constant,

$$h = 6.63 \cdot 10^{-34} \text{ J} \cdot \text{s} = 4.41 \cdot 10^{-15} \text{ eV} \cdot \text{s}$$

- Permittivity of free space,

$$\epsilon_0 = 8.85 \cdot 10^{-12} \text{ C}^2\text{/(N} \cdot \text{m}^2\text{)}$$

- Coulomb's law constant,

$$k = \frac{1}{4\pi\epsilon_0} = 8.99 \cdot 10^9 \text{ (N} \cdot \text{m}^2\text{)/C}^2$$

- Permeability of free space,

$$\mu_0 = 4\pi \cdot 10^{-7} \text{ T} \cdot \text{m/A}$$

- Magnetic constant,

$$\frac{\mu_0}{4\pi} = 1 \cdot 10^{-7} \text{ (T} \cdot \text{m)/A}$$

- 1 atmospheric pressure,

$$1 \text{ atm} = 1.01 \cdot 10^5 \text{ N/m}^2 = 1.01 \cdot 10^5 \text{ Pa}$$

- Wien's displacement constant, $b = 2.9 \cdot 10^{-3}$ m · K

- Stefan-Boltzmann constant,

$$\sigma = 5.67 \cdot 10^{-8} \text{ W/m}^2\text{/K}^4$$

Problems

1. FASTEST PATH A small toy car rolls down three ramps with the same height and horizontal length, but different shapes, starting from rest. The car stays in contact with the ramp at all times and no energy is lost. Order the ramps from the fastest to slowest time it takes for the toy car to drop the full 1 m. For example, if ramp 1 is the fastest and ramp 3 is the slowest, then enter 123 as your answer choice.

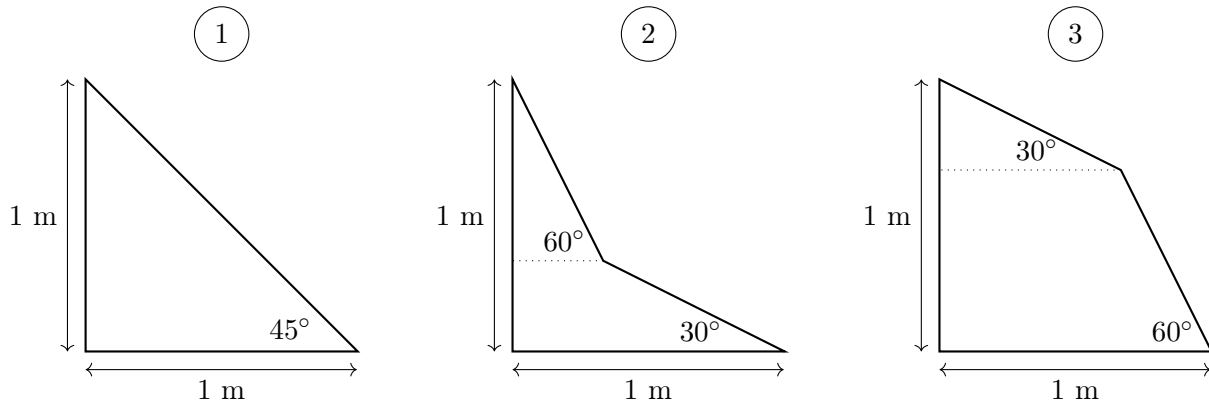

2. RESISTOR PUZZLE What is the smallest number of 1Ω resistors needed such that when arranged in a certain arrangement involving only series and parallel connections, that the equivalent resistance is $\frac{7}{6}\Omega$?

3. DERBY RACE In a typical derby race, cars start at the top of a ramp, accelerate downwards, and race on a flat track, and are always set-up in the configuration shown below.

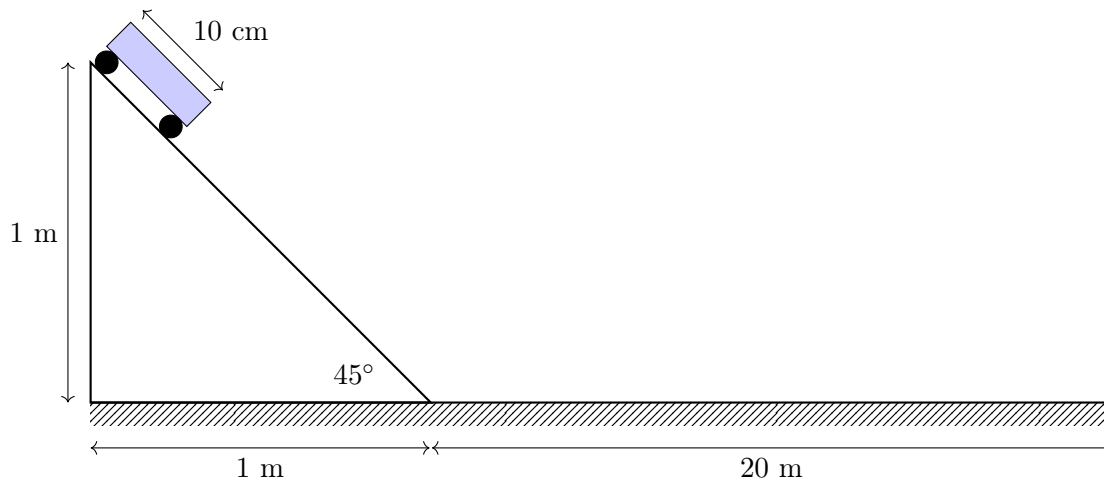

A common technique is to change the location of the center of mass of the car to gain an advantage. Alice ensures the center of mass of her car is at the rear and Bob puts the center of mass of his car at the very front. Otherwise, their cars are exactly the same. Each car's time is defined as the time from when the car is placed on the top of the ramp to when the front of the car reaches the end of the flat track. At the competition, Alice's car beat Bob's. What is the ratio of Bob's car's time and Alice's car's time?

Assume that the wheels are small and light compared to the car body, neglect air resistance, and the height of the cars are small compared to the height of the ramp. In addition, neglect all energy losses during the race and the time it takes to turn onto the horizontal surface from the ramp. Express your answer as a decimal greater than 1.

4. CRANE A simple crane is shown in the below diagram, consisted of light rods with length 1 m and $\sqrt{2}$ m. The end of the crane is supporting a 5 kN object. Point B is known as a “pin.” It is attached to the main body and can exert both a vertical and horizontal force. Point A is known as a “roller” and can only exert vertical forces. Rods can only be in pure compression or pure tension.

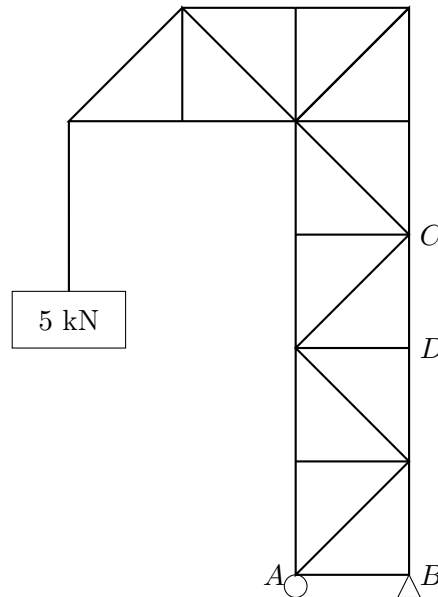

In kN, what is the force experienced by the rod CD ? Express a positive number if the member is in tension and a negative number if it is in compression.

5. COAXIAL CABLE A coaxial cable is cylindrically symmetric and consists of a solid inner cylinder of radius $a = 2$ cm and an outer cylindrical shell of inner radius $b = 5$ cm and outer radius $c = 7$ cm. A uniformly distributed current of total magnitude $I = 5$ A is flowing in the inner cylinder and a uniformly distributed current of the same magnitude but opposite direction flows in the outer shell. Find the magnitude $B(r)$ of the magnetic field B as a function of distance r from the axis of the cable. As the final result, submit $\int_0^\infty B(r)dr$. In case this is infinite, submit 42.

6. MAGNETIC BLOCK A small block of mass m and charge Q is placed at rest on an inclined plane with a slope $\alpha = 40^\circ$. The coefficient of friction between them is $\mu = 0.3$. A homogenous magnetic field of magnitude B_0 is applied perpendicular to the slope. The speed of the block after a very long time is given by $v = \beta \frac{mg}{QB_0}$. Determine β . Do not neglect the effects of gravity.

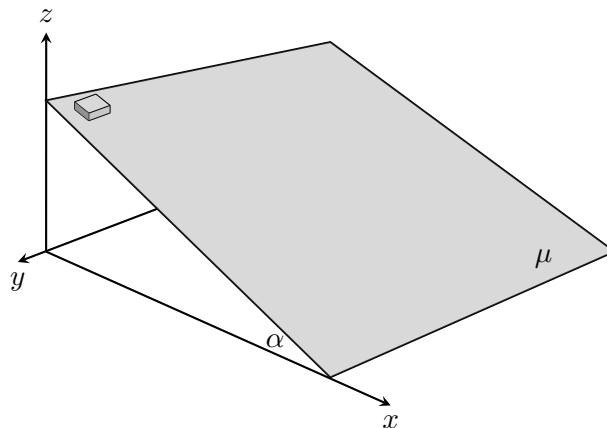

7. THERMAL TRAIN A train of length 100 m and mass 10^5 kg is travelling at 20 m/s along a straight track. The driver engages the brakes and the train starts decelerating at a constant rate, coming to a stop after travelling a distance $d = 2000$ m. As the train decelerates, energy released as heat from the brakes goes into the tracks, which have a linear heat capacity of $5000\text{J m}^{-1}\text{K}^{-1}$. Assume the rate of heat generation and transfer is uniform across the length of the train at any given moment.

If the tracks start at an ambient temperature of 20°C , there is a function $T(x)$ that describes the temperature (in Celsius) of the tracks at each point x , where the rear of where the train starts is at $x = 0$. Assume (unrealistically) that 100% of the original kinetic energy of the train is transferred to the tracks (the train does not absorb any energy), that there is no conduction of heat along the tracks, and that heat transfer between the tracks and the surroundings is negligible.

Compute $T(20) + T(500) + T(2021)$ in degrees celsius.

8. FOUNTAIN A sprinkler fountain is in the shape of a semi-sphere that spews out water from all angles at a uniform speed v such that without the presence of wind, the wetted region around the fountain forms a circle in the XY plane with the fountain centered on it.

Now suppose there is a constant wind blowing in a direction parallel to the ground such that the force acting on each water molecule is proportional to their weight. The wetted region forms the shape below where the fountain is placed at $(0,0)$. Determine the exit speed of water v in meters per second. Round to two significant digits. All dimensions are in meters.

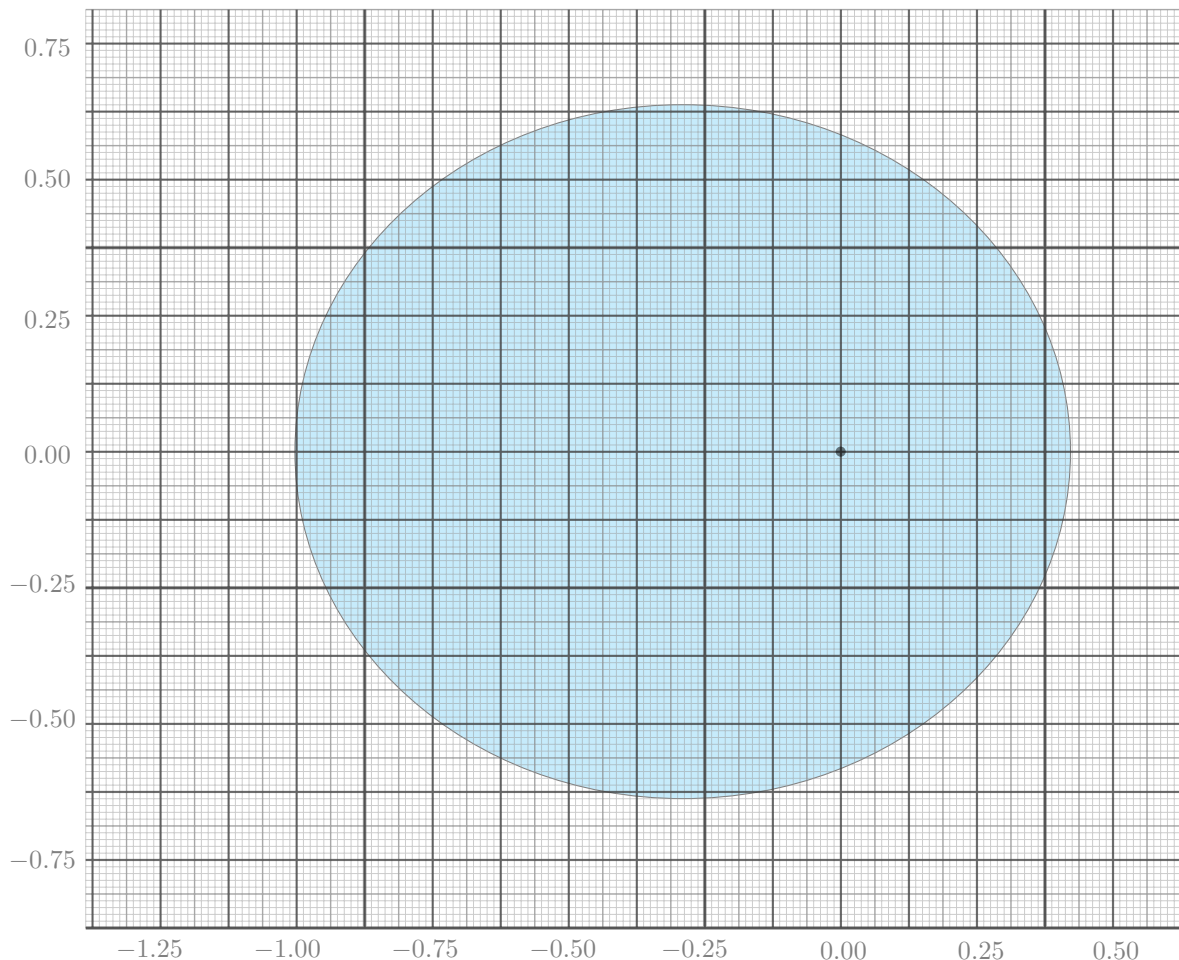

9. ESCAPING NIEONS Consider a gas of mysterious particles called nieons that all travel at the same speed, v . They are enclosed in a cubical box, and there are ρ nieons per unit volume. A very small hole of area A is punched in the side of the box. The number of nieons that escape the box per unit time is given by

$$\alpha v^\beta A^\gamma \rho^\delta \quad (1)$$

where α, β, γ , and δ are all dimensionless constants. Calculate $\alpha + \beta + \gamma + \delta$.

10. PICO-PICO 1 Poncho is a very good player of the legendary carnival game known as Pico-Pico. Its setup consists of a steel ball, represented by a point mass, of negligible radius and a frictionless vertical track. The goal of Pico-Pico is to flick the ball from the beginning of the track (point A) such that it is able to traverse through the track while never leaving the track, successfully reaching the end (point B). The most famous track design is one of parabolic shape; specifically, the giant track is of the shape $h(x) = 5 - 2x^2$ in meters. The starting and ending points of the tracks are where the two points where the track intersects $y = 0$. If $(v_a, v_b]$ is the range of the ball's initial velocity v_0 that satisfies the winning condition of Pico-Pico, help Poncho find $v_b - v_a$. This part is depicted below:

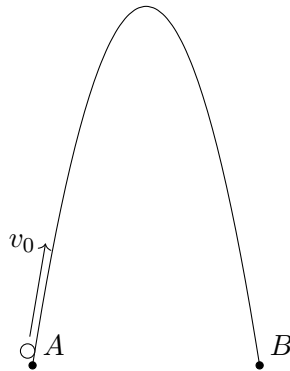

11. PICO-PICO 2 Now, Poncho has encountered a different Pico-Pico game that uses the same shaped frictionless track, but lays it horizontally on a table with friction and coefficient of friction $\mu = 0.8$. In addition, the ball, which can once again be considered a point mass, is placed on the other side of the track as the ball in part 1. Finally, a buzzer on the other side of the track requires the mass to hit with at least velocity $v_f = 2$ m/s in order to trigger the buzzer and win the game. Find the minimum velocity v_0 required for the ball to reach the end of the track with a velocity of at least v_f . The initial velocity must be directed along the track.

12. GOLDEN APPLE Anyone who's had an apple may know that pieces of an apple stick together, when picking up one piece a second piece may also come with the first piece. The same idea is tried on a *golden apple*. Consider two uniform hemispheres with radius $r = 4$ cm made of gold of density $\rho_g = 19300 \text{ kg m}^{-3}$. The top half is nailed to a support and the space between is filled with water.

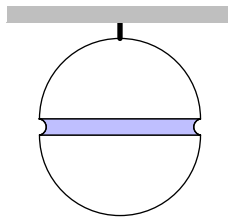

Given that the surface tension of water is $\gamma = 0.072 \text{ N m}^{-1}$ and that the contact angle between gold and water is $\theta = 10^\circ$, what is the maximum distance between the two hemispheres so that the bottom half doesn't fall? Answer in millimeters.

The following information applies to the next 2 problems. In the following two problems we will look at shooting a basketball. Model the basketball as an elastic hollow sphere with radius 0.1 meters. Model the net and basket as shown below, dimensions marked. Neglect friction between the backboard and basketball, and assume all collisions are perfectly elastic.

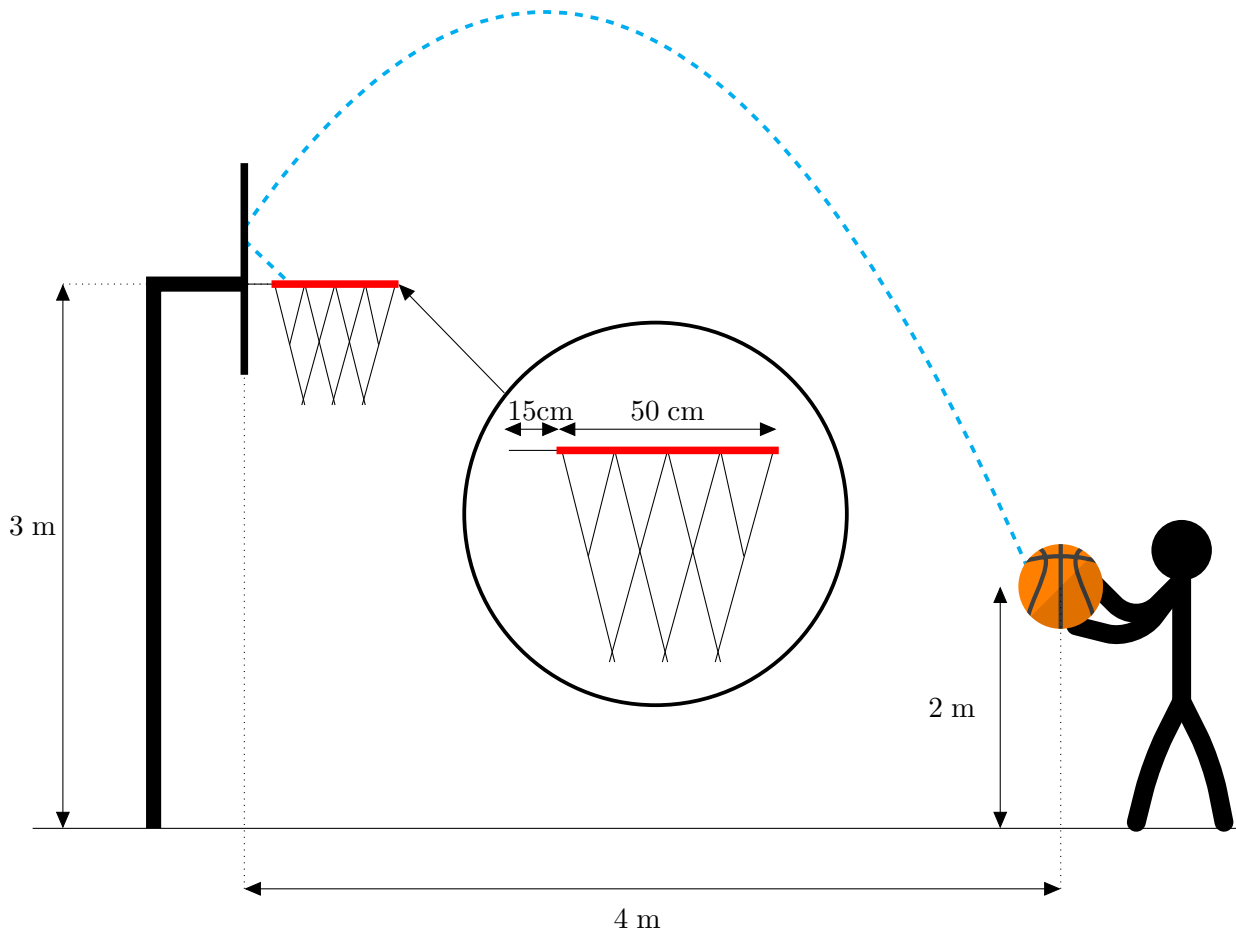

13. FREE THROW For this problem, you launch the basketball from the point that is 2 meters above the ground and 4 meters from the backboard as shown. You attempt to make a shot by hitting the basketball off the backboard as depicted above. What is the minimum initial speed required for the ball to make this shot?

Note: For this problem, you may assume that the size of the ball is negligible.

14. LAYUP You now wish to practice closer shots. You walk up until you're 1 m away from the backboard (the 4 m changes to a 1 m). You jump 1 m in the air. What is the minimum initial speed of the ball that allows you to score off of the backboard if you release the ball at the top of your jump? Note that scoring off the backboard means that the ball bounces off the backboard and into the net. Do not consider cases where the ball bounces off of the rim or the protrusion. That's just luck and you want a consistent strategy.

Hint: Neglecting the size of the ball may no longer be possible.

15. RIGHT TRIANGLE POTENTIALS Let ABC be a solid right triangle ($AB = 5s$, $AC = 12s$, and $BC = 13s$) with uniform charge density σ . Let D be the midpoint of BC . We denote the electric potential of a point P by $\phi(P)$. The electric potential at infinity is 0. If $\phi(B) + \phi(C) + \phi(D) = \frac{k\sigma s}{\epsilon_0}$ where k is a dimensionless constant, determine k .

16. TOILET PAPER ROLL Consider a toilet paper roll with some length of it hanging off as shown. The toilet paper roll rests on a cylindrical pole of radius $r = 1$ cm and the coefficient of static friction between the role and the pole is $\mu = 0.3$.

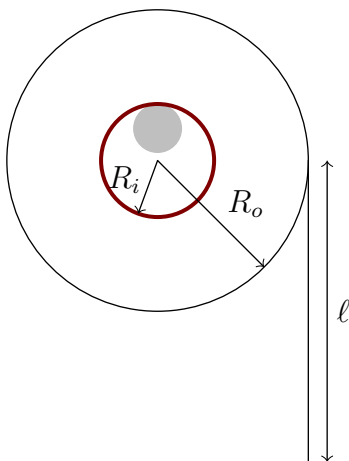

The length of the paper hanging off has length $\ell = 30$ cm and the inner radius of the roll is $R_i = 2$ cm. The toilet paper has thickness $s = 0.1$ mm and mass per unit length $\lambda = 5$ g/m. What is the minimum outer radius R_o such that the toilet paper roll remains static? Answer in centimeters.

17. MAXIMUM VOLTAGE In the circuit shown below, a capacitor $C = 4F$, inductor $L = 5H$, and resistors $R_1 = 3\Omega$ and $R_2 = 2\Omega$ are placed in a diamond shape and are then fed an alternating current with peak voltage $V_0 = 1V$ of unknown frequency. Determine the magnitude of the maximum instantaneous output voltage shown in the diagram.

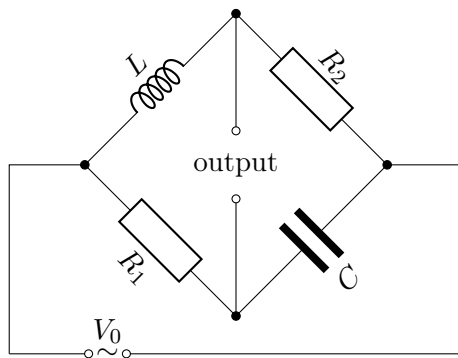

18. SUSPENDED ROD - 1 A uniform bar of length l and mass m is connected to a very long thread of negligible mass suspended from a ceiling. It is then rotated such that it is vertically upside down and then released. Initially, the rod is in unstable equilibrium. As it falls down, the minimum tension acting on the thread over the rod's entire motion is given by αmg . Determine α .

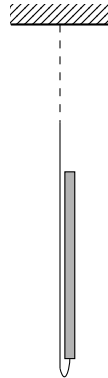

19. SUSPENDED ROD - 2 A uniform bar of length l and mass m is connected to a thread of length $2l$ of negligible mass and is suspended from the ceiling at equilibrium. The rod is then slightly nudged at a point on its body. The largest stable frequency of oscillations of the system is given by $\beta\sqrt{\frac{g}{l}}$. Determine β .

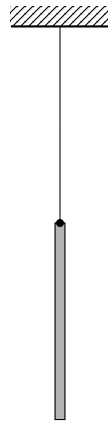

20. ONE LADDER A straight ladder AB of mass $m = 1$ kg is positioned almost vertically such that point B is in contact with the ground with a coefficient of friction $\mu = 0.15$. It is given an infinitesimal kick at the point A so that the ladder begins rotating about point B . Find the value ϕ_m of angle ϕ of the ladder with the vertical at which the lower end B starts slipping on the ground.

21. TWO LADDERS Two straight ladders AB and CD , each with length 1 m, are symmetrically placed on smooth ground, leaning on each other, such that they are touching with their ends B and C , ends A and D are touching the floor. The friction at any two surfaces is negligible. Initially both ladders are almost parallel and vertical. Find the distance AD when the points B and C lose contact.

22. COLLIDING CONDUCTING SLAB A thin conducting square slab with side length $s = 5$ cm, initial charge $q = 0.1 \mu\text{C}$, and mass $m = 100$ g is given a kick and sent bouncing between two infinite conducting plates separated by a distance $d = 0.5$ cm $\ll s$ and with surface charge density $\pm\sigma = \pm 50 \mu\text{C}/\text{m}^2$. After a long time it is observed exactly in the middle of the two plates to be traveling with velocity of magnitude $v = 3$ m/s and direction $\theta = 30^\circ$ with respect to the horizontal line parallel to the plates. How many collisions occur after it has traveled a distance $L = 15$ m horizontally from when it was last observed? Assume that all collisions are elastic, and neglect induced charges. Note that the setup is horizontal so gravity does not need to be accounted for.

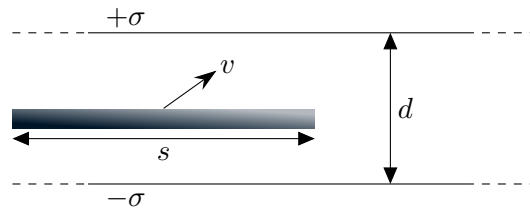

23. EVIL GAMMA PHOTON An evil gamma photon of energy $E_{\gamma 1} = 200$ keV is heading towards a spaceship. The commander's only choice is shooting another photon in the direction of the gamma photon such that they 'collide' head on and produce an electron-positron pair (both have mass m_e). Find the lower bound on the energy $E_{\gamma 2}$ of the photon as imposed by the principles of special relativity such that this occurs. Answer in keV.

24. SPINNING CYLINDER Adithya has a solid cylinder of mass $M = 10$ kg, radius $R = 0.08$ m, and height $H = 0.20$ m. He is running a test in a chamber on Earth over a distance of $d = 200$ m as shown below. Assume that the physical length of the chamber is much greater than d (i.e. the chamber extends far to the left and right of the testing area). The chamber is filled with an ideal fluid with uniform density $\rho = 700$ kg/m³. Adithya's cylinder is launched with linear velocity $v = 10$ m/s and spins counterclockwise with angular velocity ω . Adithya notices that the cylinder continues on a **horizontal path** until the end of the chamber. Find the angular velocity ω . Do not neglect forces due to fluid pressure differences. Note that the diagram presents a side view of the chamber (i.e. gravity is oriented downwards with respect to the diagram).

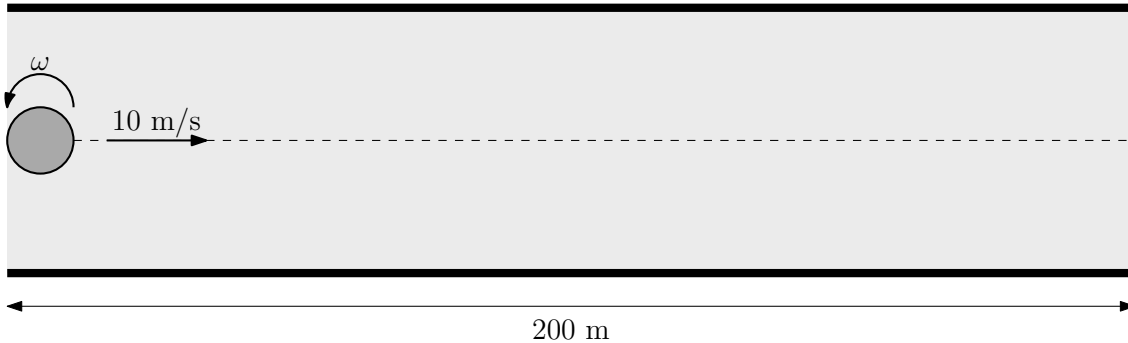

Assume the following about the setup and the ideal fluid:

- fluid flow is steady in the frame of the center of mass of the cylinder
- the ideal fluid is incompressible, irrotational, and has zero viscosity
- the angular velocity of the cylinder is approximately constant during its subsequent motion

Hint: For a uniform **cylinder** of radius R rotating counterclockwise at angular velocity ω situated in an ideal fluid with flow velocity u to the **right** far away from the cylinder, the velocity potential Φ is given by

$$\Phi(r, \theta) = ur \cos \theta + u \frac{R^2}{r} \cos \theta + \frac{\Gamma \theta}{2\pi}$$

where (r, θ) is the polar coordinate system with origin at the center of the cylinder. Γ is the circulation and is equal to $2\pi R^2 \omega$. The fluid velocity is given by

$$\mathbf{v} = \nabla \Phi = \frac{\partial \Phi}{\partial r} \hat{\mathbf{r}} + \frac{1}{r} \frac{\partial \Phi}{\partial \theta} \hat{\boldsymbol{\theta}}.$$

25. OPTIMAL LAUNCH Adithya is launching a package from New York City ($40^\circ 43'$ N and $73^\circ 56'$ W) to Guam ($13^\circ 27'$ N and $144^\circ 48'$ E). Find the minimal launch velocity v_0 from New York City to Guam. Ignore the rotation of the earth, effects due to the atmosphere, and the gravitational force from the sun. Additionally, assume the Earth is a perfect sphere with radius $R_\oplus = 6.37 \times 10^6$ m and mass $M_\oplus = 5.97 \times 10^{24}$ kg.

26. DRAG ON THE PLATE Consider a container filled with argon, with molar mass 39.9 g mol⁻¹ whose pressure is much smaller than that of atmospheric pressure. Suppose there is a plate of area $A = 10$ mm² moving with a speed v perpendicular to its plane. If the gas has density $\rho = 4.8 \times 10^{-7}$ g cm⁻³, and temperature $T = 100$ K, find an approximate value for the drag force acting on the plate. Suppose that the speed of the plate is $v = 100$ m s⁻¹.

27. SUPERCONDUCTING LOOP Consider a rectangular loop made of superconducting material with length $\ell = 200$ cm and width $w = 2$ cm. The radius of this particular wire is $r = 0.5$ mm. This superconducting rectangular loop initially has a current $I_1 = 5$ A in the counterclockwise direction as shown in the figure below. This rectangular loop is situated a distance $d = 1$ cm above an infinitely long wire that initially contains no current. Suppose that the current in the infinitely long wire is increased to some current I_2 such that there is an attractive force F between the rectangular loop and the long wire. Find the maximum possible value of F . Write your answer in newtons.

Hint: You may neglect the magnetic field produced by the vertical segments in the rectangular loop.

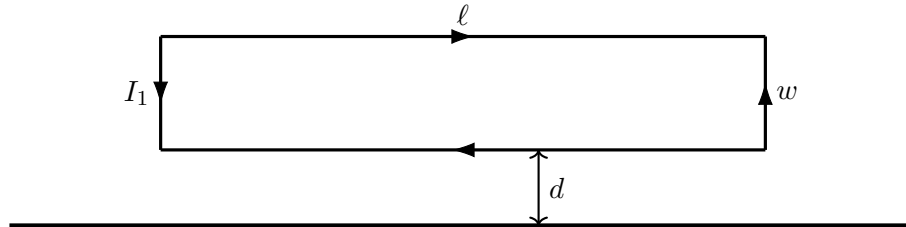

28. CANTOR INTERFERENCE Consider a 1 cm long slit with negligible height. First, we divide the slit into thirds and cover the middle third. Then, we perform the same steps on the two shorter slits. Again, we perform the same steps on the four even shorter slits and continue for a very long time.

Then, we shine a monochromatic, coherent light source of wavelength 500 nm on our slits, which creates an interference pattern on a wall 10 meters away. On the wall, what is the distance between the central maximum and the first side maximum? Assume the distance to the wall is much greater than the width of the slit. Answer in millimeters.

The following information applies to the next 2 problems. A certain planet with radius $R = 3 \times 10^4$ km is made of a liquid with constant density $\rho = 1.5$ g/cm³ with the exception of a homogeneous solid core of radius $r = 10$ km and mass $m = 2.4 \times 10^{16}$ kg. Normally, the core is situated at the geometric center of the planet. However, a small disturbance has moved the center of the core $x = 1$ km away from the geometric center of the planet. The core is released from rest, and the fluid is inviscid and incompressible.

29. SOLID CORE - 1 Calculate the magnitude of the force due to gravity that now acts on the core. Work under the assumption that $R \gg r$.

30. SOLID CORE - 2 Calculate the magnitude of the force due to the pressure from the liquid that now acts on the core.

31. SOLENOIDS A scientist is doing an experiment with a setup consisting of 2 ideal solenoids that share the same axis. The lengths of the solenoids are both ℓ , the radii of the solenoids are r and $2r$, and the smaller solenoid is completely inside the larger one. Suppose that the solenoids share the same (constant) current I , but the inner solenoid has $4N$ loops while the outer one has N , and they have opposite polarities (meaning the current is clockwise in one solenoid but counterclockwise in the other).

Model the Earth's magnetic field as one produced by a magnetic dipole centered in the Earth's core. Let F be the magnitude of the total magnetic force the whole setup feels due to Earth's magnetic field. Now the scientist replaces the setup with a similar one: the only differences are that the radii of the solenoids are $2r$ (inner) and $3r$ (outer), the length of each solenoid is 7ℓ , and the number of loops each solenoid is $27N$ (inner) and $12N$ (outer). The scientist now drives a constant current $2I$ through the setup (the solenoids still have opposite polarities), and the whole setup feels a total force of magnitude F' due to the Earth's magnetic field. Assuming the new setup was in the same location on Earth and had the same orientation as the old one, find F'/F .

Assume the dimensions of the solenoids are much smaller than the radius of the Earth.

The following information applies to the next 2 problems. Adithya is in a rocket with proper acceleration $a_0 = 3.00 \times 10^8 \text{ m/s}^2$ to the right, and Eddie is in a rocket with proper acceleration $\frac{a_0}{2}$ to the left. Let the frame of Adithya's rocket be S_1 , and the frame of Eddie's rocket be S_2 . Initially, both rockets are at rest with respect to each other, and Adithya's clock and Eddie's clock are both set to 0.

32. ACCELERATING ROCKETS - 1 At the moment Adithya's clock reaches 0.75 s in S_2 , what is the **velocity** of Adithya's rocket in S_2 ?

33. ACCELERATING ROCKETS - 2 At the moment Adithya's clock reaches 0.75 s in S_2 , what is the **acceleration** of Adithya's rocket in S_2 ?

The following information applies to the next 2 problems. Suppose a ping pong ball of radius R , thickness t , made out of a material with density ρ_b , and Young's modulus Y , is hit so that it resonates in mid-air with small amplitude oscillations. Assume $t \ll R$. The density of air around (and inside) the ball is ρ_a , and the air pressure is p , where $\rho_a \ll \rho_b \frac{t}{R}$ and $p \ll Y \frac{t^3}{R^3}$.

34. PING PONG - 1 An estimate for the resonance frequency is $\omega \sim R^a t^b \rho_b^c Y^d$. Find the value of $4a^2 + 3b^2 + 2c^2 + d^2$.

Hint: The surface of the ball will oscillate by "bending" instead of "stretching", since the former takes much less energy than the latter.

35. PING PONG - 2 Assuming that the ball loses mechanical energy only through the surrounding air, find an estimate of the characteristic time τ it takes for the ball to stop resonating (or to lose half its mechanical energy), that is $\tau \sim R^\alpha t^\beta \rho_b^\kappa Y^\delta \rho_a^\zeta p^\gamma$. Find the value of $6\alpha^2 + 5\beta^2 + 4\kappa^2 + 3\delta^2 + 2\zeta^2 + \gamma^2$. (Note that in reality, the ball also loses mechanical energy to heat, but we will neglect that for simplicity.)