

2020 Online Physics Olympiad (OPhO): Open Contest v1.5

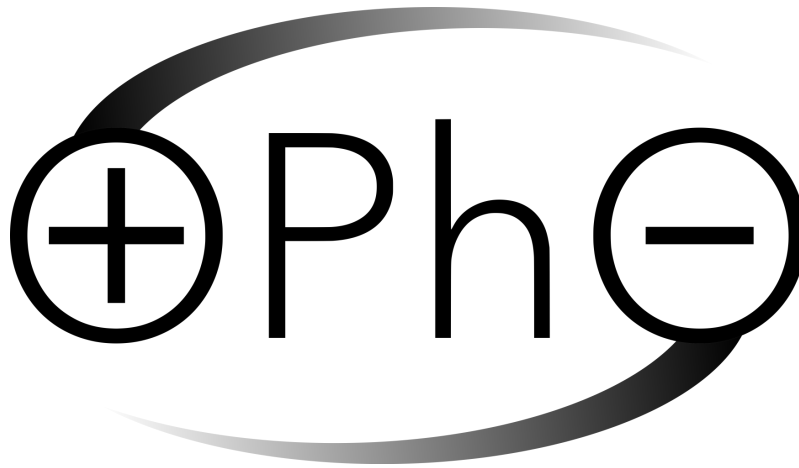

OPhO Lead Organizers and Writers: Adithya Balachandran, Eddie Chen, Ashmit Dutta, Ethan Hu, Viraj Jayam, Rishab Parthasarathy, Kushal Thaman, Max Wang, QiLin Xue

OPhO Website Developer: Ben Oommen

Advisors: Dr. Branislav Kisačanin, Kye Shi, Kevin Zhou

Instructions

If you wish to request a clarification, please use [this form](#). To see all clarifications, see [this document](#).

- Use $g = 9.81 \text{ m/s}^2$ in this contest. See the constants sheet on the following page for other constants.
- This test contains 55 short answer questions. Each problem will have three possible attempts.
- The weight of each question depends on our scoring system found [here](#). Put simply, the later questions are worth more, and the overall amount of points from a certain question decreases with the number of attempts and days that you take to solve a problem as well as the number of teams who solve it. This means that your score decreases with the number of tries and days you take to solve a given problem.
- Any team member is able to submit an attempt. Choosing to split up the work or doing each problem together is up to you. Note that after you have submitted an attempt, your teammates must refresh their page before they are able to see it.
- Answers should contain at least **three** significant figures, unless otherwise specified. All answers within the 1% range will be accepted.
- When submitting a response using scientific notation, please use exponential form. In other words, if your answer to a problem is $A \times 10^B$, please type AeB into the submission portal.
- A standard scientific or graphing handheld calculator *may* be used. Technology and computer algebra systems like Wolfram Alpha or the one in the TI nSpire will not be needed. Attempts to use these tools will be classified as cheating.
- You are *allowed* to use Wikipedia or books in this exam. Asking for help on online forums or your teachers will be considered cheating and may result in a possible ban from future competitions.
- Top scorers from this contest will qualify to compete in the Online Physics Olympiad *Invitational Contest*, which is an olympiad-style exam. More information will be provided to invitational qualifiers after the end of the *Open Contest*.
- In general, answer in SI units (meter, second, kilogram, watt) unless otherwise specified. Please answer all questions in degrees unless otherwise specified.
- If the question asks to give your answer as a percent and your answer comes out to be “ $x\%$ ”, please input the value x into the submission form.
- Do not put letters in your answer on the submission portal! If your answer is “ x meters”, input only the value x into the submission portal.
- **Do not communicate information to anyone else apart from your team-members before the exam ends on May 29, 2020 at 11:59 PM UTC.**

Sponsors

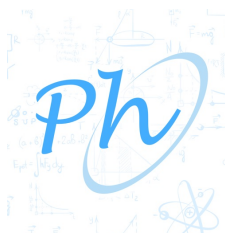

List of Constants

- Proton mass, $m_p = 1.67 \cdot 10^{-27}$ kg
- Neutron mass, $m_n = 1.67 \cdot 10^{-27}$ kg
- Electron mass, $m_e = 9.11 \cdot 10^{-31}$ kg
- Avogadro's constant, $N_0 = 6.02 \cdot 10^{23}$ mol⁻¹
- Universal gas constant, $R = 8.31$ J/(mol · K)
- Boltzmann's constant, $k_B = 1.38 \cdot 10^{-23}$ J/K
- Electron charge magnitude, $e = 1.60 \cdot 10^{-19}$
- 1 electron volt, $1 \text{ eV} = 1.60 \cdot 10^{-19}$ J
- Speed of light, $c = 3.00 \cdot 10^8$ m/s
- Universal Gravitational constant,

$$G = 6.67 \cdot 10^{-11} \text{ (N} \cdot \text{m}^2\text{)/kg}^2$$
- Acceleration due to gravity, $g = 9.81$ m/s²
- 1 unified atomic mass unit,

$$1 \text{ u} = 1.66 \cdot 10^{-27} \text{ kg} = 931 \text{ MeV}/c^2$$
- Planck's constant,

$$h = 6.63 \cdot 10^{-34} \text{ J} \cdot \text{s} = 4.41 \cdot 10^{-15} \text{ eV} \cdot \text{s}$$

- Permittivity of free space,

$$\epsilon_0 = 8.85 \cdot 10^{-12} \text{ C}^2/(\text{N} \cdot \text{m}^2)$$

- Coulomb's law constant,

$$k = \frac{1}{4\pi\epsilon_0} = 8.99 \cdot 10^9 \text{ (N} \cdot \text{m}^2\text{)/C}^2$$

- Permeability of free space, $\mu_0 = 4\pi \cdot 10^{-7}$ T · m/A

- Magnetic constant,

$$\frac{\mu_0}{4\pi} = 1 \cdot 10^{-7} \text{ (T} \cdot \text{m)/A}$$

- 1 atmospheric pressure,

$$1 \text{ atm} = 1.01 \cdot 10^5 \text{ N/m}^2 = 1.01 \cdot 10^5 \text{ Pa}$$

- Wien's displacement constant, $b = 2.9 \cdot 10^{-3}$ m · K

- Stefan-Boltzmann constant,

$$\sigma = 5.67 \cdot 10^{-8} \text{ W/m}^2\text{/K}^4$$

Problems

Pr 1. Angry Birds

A quarantined physics student decides to perform an experiment to land a small box of mass $m = 60$ g onto the center of a target a distance Δd away. The student puts the box on a top of a frictionless ramp with height $h_2 = 0.5$ m that is angled $\theta = 30^\circ$ to the horizontal on a table that is $h_1 = 4$ m above the floor. If the student pushes the spring with spring constant $k = 6.5$ N/m down by $\Delta x = 0.3$ m compared to its rest length and lands the box exactly on the target, what is Δd ? Answer in meters. You may assume friction is negligible.

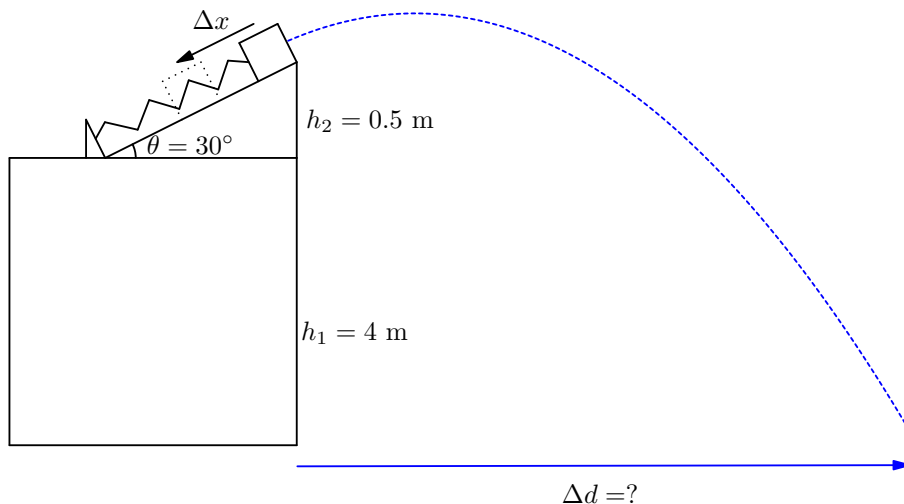

Pr 2. The Wheels on the Monster Truck go Round and Round

A wooden bus of mass $M = 20,000$ kg (M represents the mass excluding the wheels) is on a ramp with angle 30° . Each of the four wheels is composed of a ring of mass $\frac{M}{2}$ and radius $R = 1$ m and 6 evenly spaced spokes of mass $\frac{M}{6}$ and length R . All components of the truck have a uniform density. Find the acceleration of the bus down the ramp assuming that it rolls without slipping.

Answer in m/s^2 .

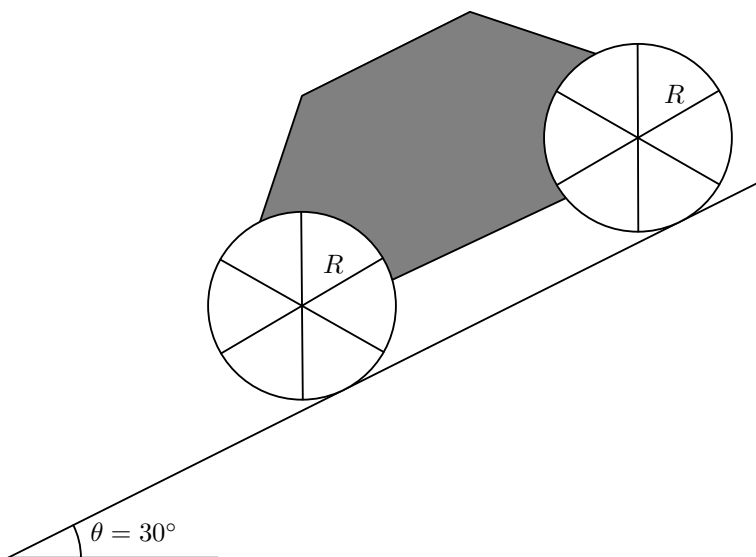

Pr 3. Don't make me reach my Tipping Point

THIS QUESTION HAS BEEN REMOVED FROM THE EXAM.

Pr 4. District 12

In an old coal factory, a conveyor belt will move at a constant velocity of 20.3 m/s and can deliver a maximum power of 15 MW. Each wheel in the conveyor belt has a diameter of 2 m. However a changing demand has pushed the coal factory to fill their coal hoppers with a different material with a certain constant specific density. These "coal" hoppers have been modified to deliver a constant $18 \text{ m}^3\text{s}^{-1}$ of the new material to the conveyor belt. Assume that the kinetic and static friction are the same and that there is no slippage. What is the maximum density of the material?

Pr 5. Neutrino Party

Neutrinos are extremely light particles and rarely interact with matter. The Sun emits neutrinos, each with an energy of $8 \times 10^{-14} \text{ J}$ and reaches a flux density of $10^{11} \text{ neutrinos}/(\text{s cm}^2)$ at Earth's surface.

In the movie *2012*, neutrinos have mutated and now are completely absorbed by the Earth's inner core, heating it up. Model the inner core as a sphere of radius 1200 km, density 12.8 g/cm^3 , and a specific heat of 0.400 J/g K . The time scale, in seconds, that it will take to heat up the inner core by 1°C is $t = 1 \times 10^N$ where N is an integer. What is the value of N ?

Pr 6. Quarantine Secrets

A ball is situated at the midpoint of the bottom of a rectangular ditch with width 1 m. It is shot at a velocity $v = 5 \text{ m/s}$ at an angle of 30° relative to the horizontal. How many times does the ball collide with the walls of the ditch until it hits the bottom of the ditch again? Assume all collisions to be elastic and that the ball never flies out of the ditch.

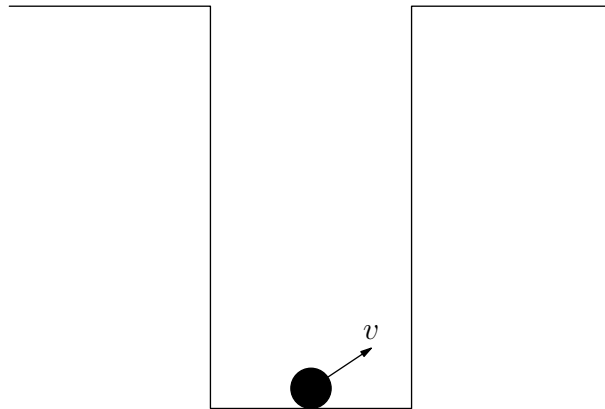

Pr 7. Planetary Proton

Professor Proton has discovered a new planet on one of his planetary expeditions. He wants to measure the magnetic field of the planet he has found. Professor Proton has brought all the necessary equipment required to carry out the following experiment. A proton is launched off a large cliff at a non-relativistic speed v and an angle $\theta = 30^\circ$ with respect to the horizontal plane at the magnetic equator of a distant planet. The magnetic field acting perpendicularly on the particle can be assumed to be perfectly horizontal and coming out of the page, as shown in the diagram. How strong is the magnetic field at the magnetic equator of this planet if the period of oscillation of v_x is 4.94×10^{-4} s? Write your answer in terms of μT (micro-Teslas).

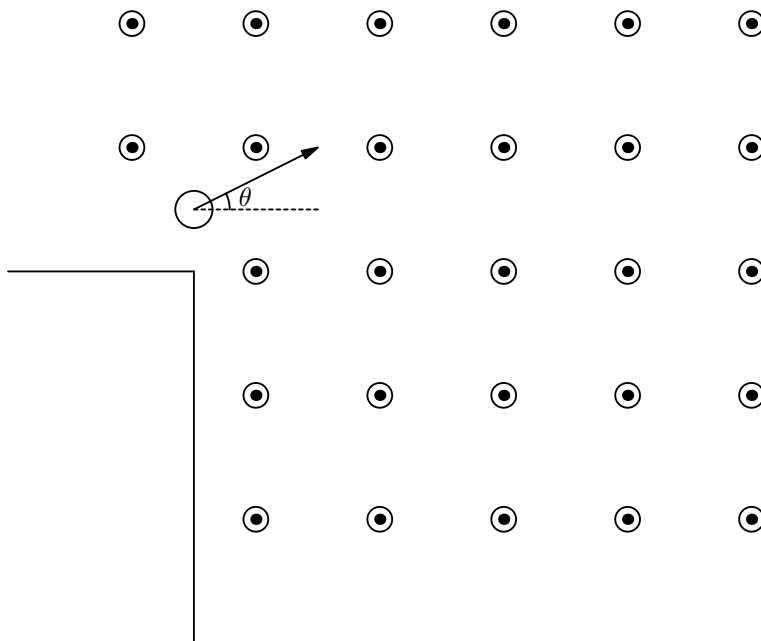

Pr 8. Angel Coaster

A frictionless track contains a loop of radius $R = 0.5$ m. Situated on top of the track lies a small ball of mass $m = 2$ kg at a height h . It is then dropped and collides with another ball (of negligible size) of mass $M = 5$ kg.

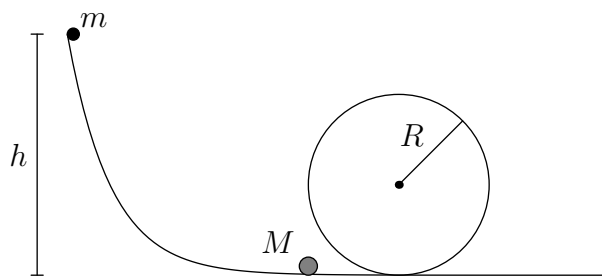

Let h be the minimum height that m was dropped such that M would be able to move all the way around the loop. The coefficient of restitution for this collision is given as $e = \frac{1}{2}$.

Now consider a different scenario. Assume that the balls can now collide perfectly inelastically, which means that they stick to each other instantaneously after collision for the rest of the motion. If m was dropped from a height $3R$, find the minimum value of $\frac{m}{M}$ such that the combined mass can fully move all the way around the loop. Let this minimum value be k . Compute $\alpha = \frac{k^2}{h^2}$. (Note that this question is *only* asking for α but you need to find h to find α). Assume the balls are point masses (neglect rotational effects).

Pr 9. Wannabe Twoset

Eddie is experimenting with his sister's violin. Allow the "A" string of his sister's violin have an ultimate tensile strength σ_1 . He tunes a string up to its highest possible frequency f_1 before it breaks. He then builds an exact copy of the violin, where all lengths have been increased by a factor of $\sqrt{2}$ and tunes the same string again to its highest possible frequency f_2 . What is f_2/f_1 ? The density of the string does not change.

Note: The ultimate tensile strength is maximum amount of stress an object can endure without breaking. Stress is defined as $\frac{F}{A}$, or force per unit area.

Pr 10. Waterhorse or Flyinghorse

A one horsepower propeller powered by a battery and is used to propel a small boat initially at rest. You have two options:

1. Put the propeller on top of the boat and push on the air with an initial force F_1
2. Put the propeller underwater and push on the water with an initial force F_2 .

The density of water is 997 kg/m^3 while the density of air is 1.23 kg/m^3 . Assume that the force in both cases is dependent upon only the density of the medium, the surface area of the propeller, and the power delivered by the battery. What is F_2/F_1 ? You may assume (unrealistically) the efficiency of the propeller does not change. Round to the nearest tenths.

Pr 11. Charlie And The Chocolate Factory

A professional pastry chef is making a sweet which consists of 3 sheets of chocolate. The chef leaves a gap with width $d_1 = 0.1 \text{ m}$ between the top and middle layers and fills it with a chocolate syrup with uniform viscosity $\eta_1 = 10 \text{ Pa} \cdot \text{s}$ and a gap with width $d_2 = 0.2 \text{ m}$ between the middle and bottom sheet and fills it with caramel with uniform viscosity $\eta_2 = 15 \text{ Pa} \cdot \text{s}$. If the chef pulls the top sheet with a velocity 2 m/s horizontally, at what speed must he push the bottom sheet horizontally such that the middle sheet remains stationary initially? Ignore the weight of the pastry sheets throughout the problem and assume the sheets are equally sized.

Note: Shear stress is governed by the equation $\tau = \eta \times \text{rate of strain}$.

Pr 12. Loopy Wire

The following diagram depicts a single wire that is bent into the shape below. The circuit is placed in a magnetic field pointing out of the page, uniformly increasing at the rate $\frac{dB}{dt} = 2.34 \text{ T/s}$. Calculate the magnitude of induced electromotive force in the wire, in terms of the following labelled areas (m^2). Note that B is non-inclusive of C and that $A = 4.23$, $B = 2.74$, and $C = 0.34$.

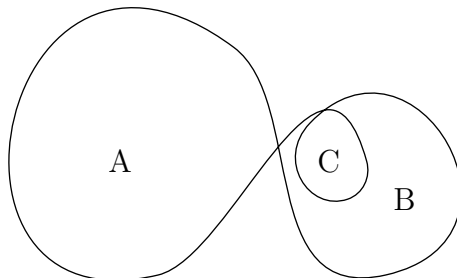

The following information applies to the next two problems. A magnetic field is located within a region enclosed by an elliptical island with semi-minor axis of $a = 100$ m and semi-major axis of $b = 200$ m. A car carrying charge $+Q = 1.5$ C drives on the boundary of the island at a constant speed of $v = 5$ m/s and has mass $m = 2000$ kg. Any dimensions of the car can be assumed to be much smaller than the dimensions of the island. Ignore any contributions to the magnetic field from the moving car and assume that the car has enough traction to continue driving in its elliptical path.

Let the center of the island be located at the point $(0,0)$ while the semi major and semi minor axes lie on the x and y -axes, respectively.

On this island, the magnetic field varies as a function of x and y : $B(x,y) = k_b e^{c_b xy} \hat{z}$ (pointing in the upward direction, perpendicular to the island plane in the positive z -direction). The constant $c_b = 10^{-4}$ m $^{-2}$ and the constant $k_b = 2.1$ μ T

Pr 13. Journey 2: The Magnetic Island 1

At what point on the island is the force from the magnetic field a maximum? Write the distance of this point from the x -axis in metres.

Pr 14. Journey 2: The Magnetic Island 2

Assuming no slipping, what is the magnitude of the net force on the car at the point of the maximum magnetic field? (Answer in Newtons.)

Pr 15. Tuning Outside

Inside a laboratory at room temperature, a steel tuning fork in the shape of a U is struck and begins to vibrate at $f = 426$ Hz. The tuning fork is then brought outside where it is 10°C hotter and the experiment is performed again. What is the change in frequency, Δf of the tuning fork? (A positive value will indicate an increase in frequency, and a negative value will indicate a decrease.)

Note: The linear thermal coefficient of expansion for steel is $\alpha = 1.5 \times 10^{-5}$ K $^{-1}$ and you may assume the expansion is isotropic and linear. When the steel bends, there is a restoring torque $\tau = -\kappa\theta$ such that $\kappa \equiv GJ$ where $G = 77$ GPa is constant and J depends on the geometry and dimensions of the cross-sectional area.

Pr 16. Too Much Potential

A large metal conducting sphere with radius 10 m at an initial potential of 0 and an infinite supply of smaller conducting spheres of radius 1 m and potential 10 V are placed into contact in such a way: the large metal conducting sphere is contacted with each smaller sphere one at a time. You may also assume the spheres are touched using a thin conducting wire that places the two spheres sufficiently far away from each other such that their own spherical charge symmetry is maintained. What is the least number of smaller spheres required to be touched with the larger sphere such that the potential of the larger sphere reaches 9 V? Assume that the charges distribute slowly and that the point of contact between the rod and the spheres is not a sharp point.

Pr 17. Particle in the Box

During high speed motion in a strong electric field, a charged particle can ionize air molecules it collides with.

A charged particle of mass $m = 0.1$ kg and charge $q = 0.5$ μ C is located in the center of a cubical box. Each vertex of the box is fixed in space and has a charge of $Q = -4$ μ C. If the side length of the box is $l = 1.5$ m what minimum speed (parallel to an edge) should be given to the particle for it to exit the box (even if it's just momentarily)? Let the energy loss from Corona discharge and other radiation effects be $E = 0.00250$ J.

Pr 18. Room of Mirrors 1

Max finds himself trapped in the center of a mirror walled equilateral triangular room. What minimum beam angle must his flashlight have so that any point of illumination in the room can be traced back to his flashlight with at most 1 bounce? (Answer in degrees.) Since the room is large, assume the person is a point does not block light. Visualize the questions in a 2D setup. The floor/ceiling is irrelevant.

The point of illumination refers to any point in the room that is lit.

Pr 19. Room of Mirrors 2

Max is again trapped at the center of the same room (from the previous problem) but with a much less powerful flashlight. What minimum beam angle must his flashlight have so that any point of illumination in the room can be traced back to his flashlight with at most 100 bounces? (Answer in degrees.)

Pr 20. Secret Society

For his art project, Weishaupt cut out $N = 20$ wooden equilateral triangular blocks with a side length of $\ell = 10$ cm and a thickness of $t = 2$ cm, each with the same mass and uniform density. He wishes to stack one on top of the other overhanging the edge of his table. In centimeters, what is the maximum overhang? Round to the nearest centimeter. A side view is shown below. Assume that all triangles are parallel to each other.

Note: This diagram is not to scale.

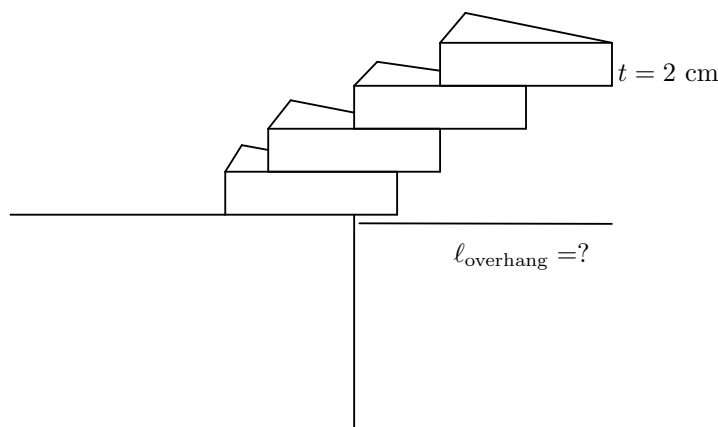

The following information applies to the following three problems. Kushal finds himself trapped in a large room with mirrors as walls. Being scared of the dark, he has a powerful flashlight to light the room. All references to "percent" refer to area. Since the room is large, assume the person is a point does not block light. Visualize the questions in a 2D setup. The floor/ceiling is irrelevant. *The point of illumination refers to any point in the room that is lit.*

Pr 21. Focus On That Not This! 1

What percent of a large circular room can be lit up using a flashlight with a 20 degree beam angle if Kushal stands in the center?

Pr 22. Focus On That Not This! 2

Kushal stands at a focus of an elliptical room with eccentricity 0.5 and semi major axis = 20 m. He points the flashlight along the semi-major axis away from the other focus. Find the ideal position where the torch can be placed to catch fire easily by the beam from the flashlight. What is the distance from this point to Kushal? Note that the torch cannot be at the same location as the flashlight. (Answer in metres.)

Pr 23. Focus On That Not This! 3

Now Kushal stands at a focus of the same elliptical room as in Problem 22. Determine the minimum percent of the elliptical room that can be lit up with a flashlight of beam angle 1 degree.

Pr 24. Two Star Crossed Lovers...

Two identical neutron stars with mass $m = 4 \times 10^{30}$ kg and radius 15 km are orbiting each other a distance $d = 700$ km away from each other (d refers to the initial distance between the cores of the neutron stars). Assume that they orbit as predicted by classical mechanics, except that they generate gravitational waves. The power dissipated through these waves is given by:

$$P = \frac{32G^4}{5} \left(\frac{m}{dc}\right)^5$$

How long does it take for the two stars to collide? Answer in seconds. *Note:* d is the distance between the *cores* of the stars.

Pr 25. Too Bored

The graph provided plots the y -component of the velocity against the x -component of the velocity of a kiddie roller coaster at an amusement park for a certain duration of time. The ride takes place entirely in a two dimensional plane.

Some students made a remark that at one time, the acceleration was perpendicular to the velocity. Using this graph, what is the minimum x -velocity the ride could be travelling at for this to be true? Round to the nearest integer and answer in meters per second. The diagram is drawn to scale, and you may print this page out and make measurements.

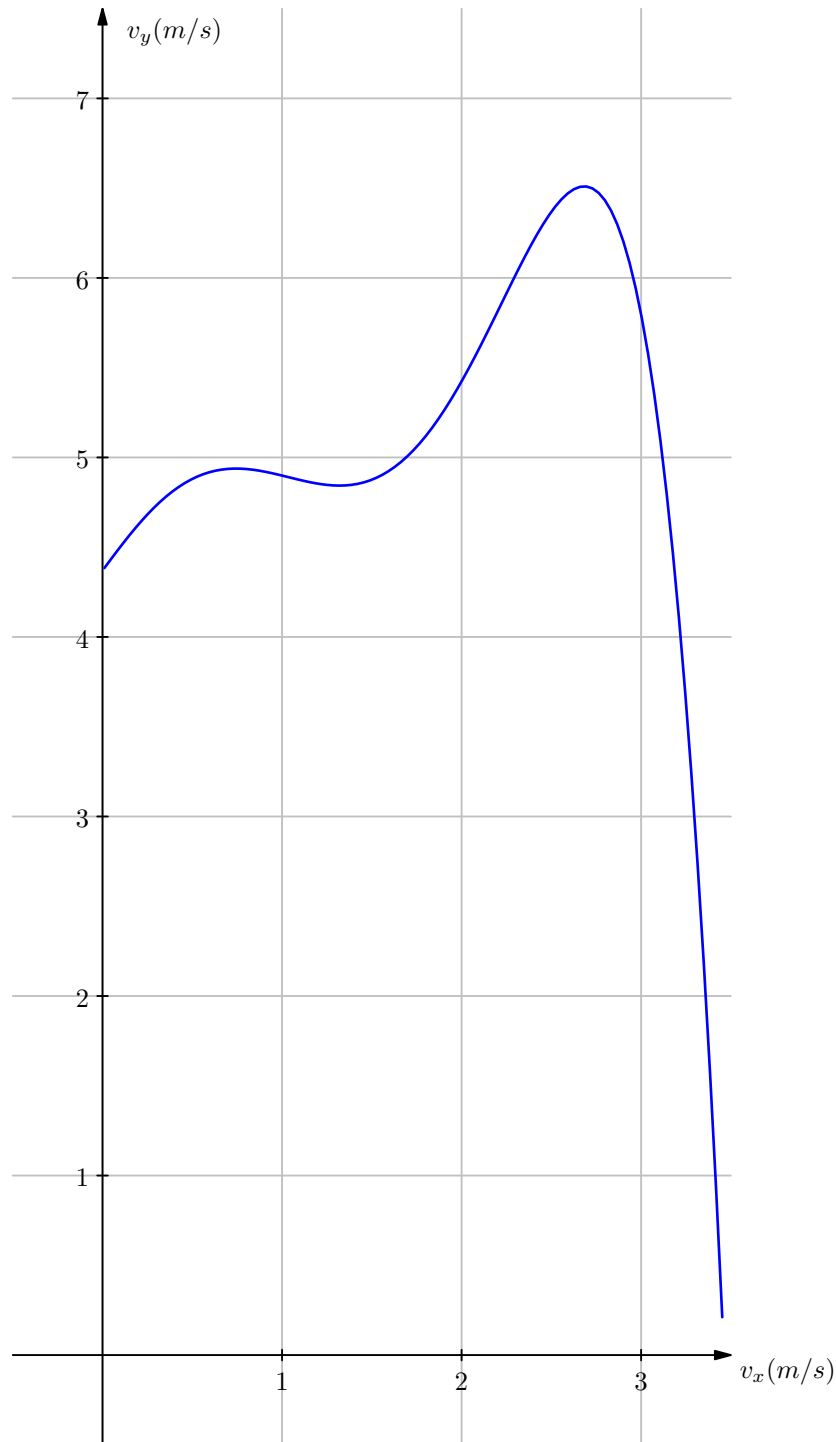

The following information applies to the next two problems: In the cosmic galaxy, the Sun is a main-sequence star, generating its energy mainly by nuclear fusion of hydrogen nuclei into helium. In its core, the Sun fuses hydrogen to produce deuterium (${}^2\text{H}$) and tritium (${}^3\text{H}$), then makes about 600 million metric tons of helium (${}^4\text{He}$) per second. Of course, there are also some relatively smaller portions of fission reactions in the Sun's core, e.g. a nuclear fission reaction with Uranium-235 (${}^{235}\text{U}$). The Fusion reaction:

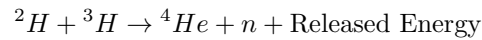

The Fission reaction:

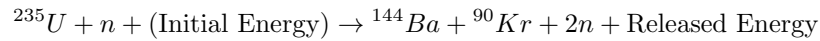

Isotope Mass (at rest)

Isotope Names	Mass (at rest) (u)
Deuterium (${}^2\text{H}$)	2.0141
Tritium (${}^3\text{H}$)	3.0160
Helium (${}^4\text{He}$)	4.0026
Neutron (n)	1.0087
Uranium-235 (${}^{235}\text{U}$)	235.1180
Barium-144 (${}^{144}\text{Ba}$)	143.8812
Krypton-90 (${}^{90}\text{Kr}$)	89.9471

Pr 26. You are my Sunshine 1

Calculate the kinetic energy (in MeV) released by the products in one fusion reaction.

Pr 27. You are my Sunshine 2

Calculate the energy produced in the core of the Sun per second from helium fusion. Answer in Joules.

Pr 28. Be Reflected It Must

While exploring outer space, Darth Vader comes upon a purely reflective spherical planet with radius $R_p = 40,000$ m and mass $M_p = 8.128 \times 10^{24}$ kg. Around the planet is a strange moon of orbital radius $R_s = 6,400,000$ m ($R_s \gg R_p$) and mass $M_s = 9.346 \times 10^{19}$ kg ($M_s \ll M_p$). The moon can be modelled as a blackbody and absorbs light perfectly. Darth Vader is in the same plane that the planet orbits in. Startled, Darth Vader shoots a laser with constant intensity and power $P_0 = 2 \times 10^{32}$ W at the reflective planet and hits the planet a distance of $\frac{R_p}{2}$ away from the line from him to the center of the planet. Upon hitting the reflective planet, the light from the laser is plane polarized. The angle of the planet's polarizer is always the same as the angle of reflection. After reflectance, the laser lands a direct hit on the insulator planet. Darth Vader locks the laser in on the planet until it moves right in front of him, when he turns the laser off. Determine the energy absorbed by the satellite. Assume the reflective planet remains stationary and that the reflective planet is a perfect polarizer of light.

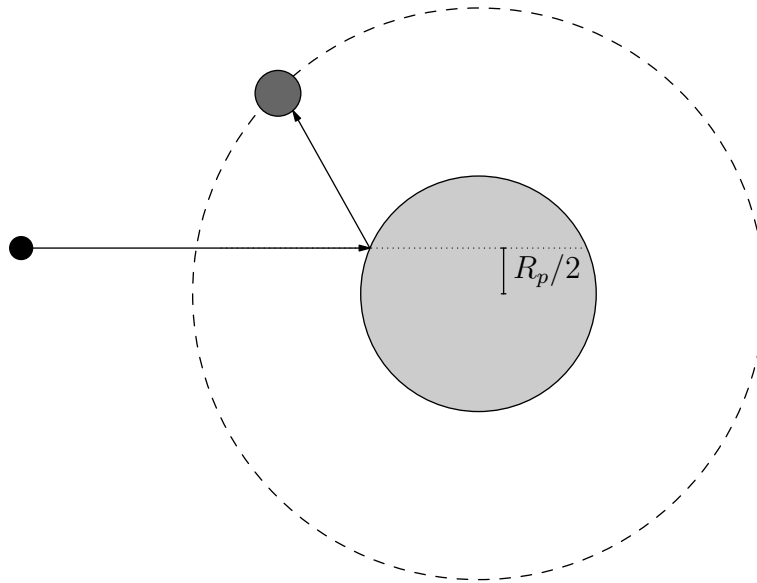

Pr 29. Braking Up

A particle of rest mass m moving at a speed $v = 0.7c$ decomposes into two photons which fly off at a separated angle θ . What is the minimum value of the angle of separation assuming that the two photons have equal wavelength. (Answer in degrees)

Pr 30. With Great Power

Mario is racing with Wario on Moo Moo Meadows when a goomba, ready to avenge all of his friends' deaths, came and hijacked Mario's kart. A graph representing the motion of Mario at any instant is shown below. The velocity acquired by Mario is shown on the x-axis, and the net power of his movement is shown on the y-axis. When Mario's velocity is 6 m/s, he eats a mushroom which gives him a super boost.

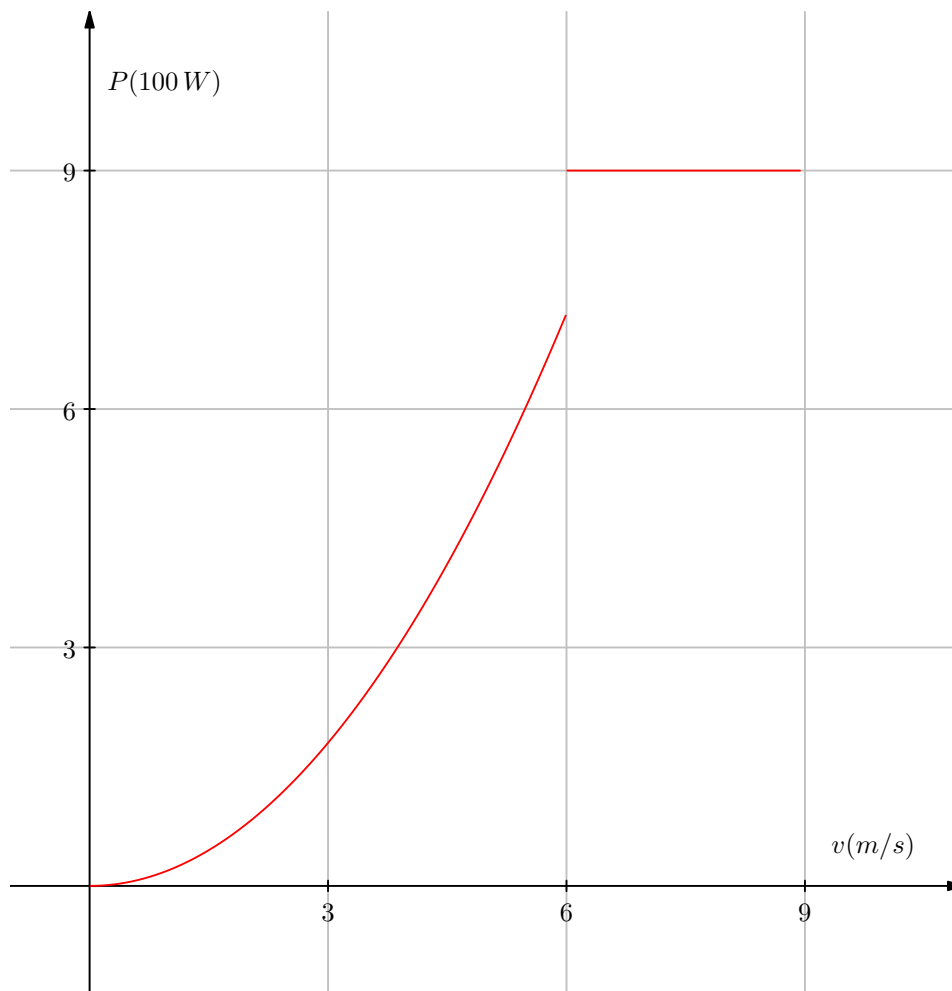

You may need to make measurements. Feel free to print this picture out as the diagram is drawn to scale. Find the total distance from Mario runs from when his velocity is 0 m/s to when his velocity just reaches 9 m/s given that Mario's mass is $m = 89$ kg. Answer in meters and round to one significant digit.

Pr 31. I'm a little teacup

At an amusement park, there is a ride with three "teacups" that are circular with identical dimensions. Three friends, Ethan, Rishab, and Kushal, all pick a teacup and sit at the edge. Each teacup rotates about its own axis clockwise at an angular speed $\omega = 1$ rad/s and can also move linearly at the same time.

The teacup Ethan is sitting on (as always) is malfunctional and can only rotate about its own axis. Rishab's teacup is moving linearly at a constant velocity 2 m/s [N] and Kushal's teacup is also moving linearly at a constant velocity of 4 m/s [N 60° E]. All three teacups are rotating as described above. Interestingly, they observe that at some point, all three of them are moving at the same velocity. What is the radius of each teacup?

Note: [N 60° E] means 60° clockwise from north e.g. 60° east of north.

Pr 32. Tetrahedron Resistance

An engineer has access to a tetrahedron building block with side length $\ell = 10$ cm. The body is made of a thermal insulator but the edges are wrapped with a thin copper wiring with cross sectional area $S = 2$ cm². The thermal conductivity of copper is 385.0 W/(m K). He stacks these tetrahedrons (all facing the same direction) to form a large lattice such that the copper wires are all in contact. In the diagram, only the front row of a small section is coloured. Assume that the lattice formed is infinitely large.

At some location in the tetrahedral building block, the temperature difference between two adjacent points is 1°C. What is the heat flow across these two points? Answer in Watts.

Note: Two adjacent points refer to two adjacent points on the tetrahedron.

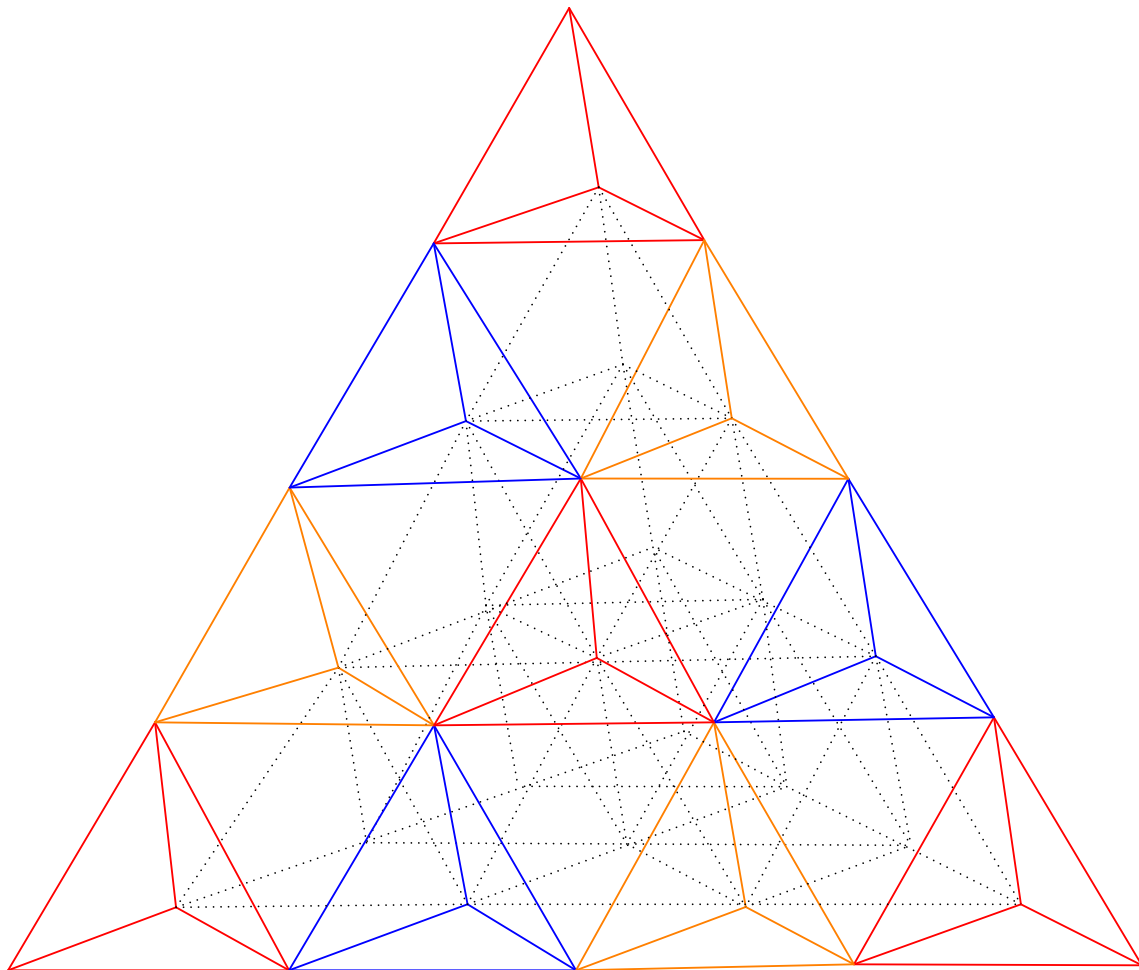

Pr 33. AIME

Three unit circles, each with radius 1 meter, lie in the same plane such that the center of each circle is one intersection point between the two other circles, as shown below. Mass is uniformly distributed among all area enclosed by at least one circle. The mass of the region enclosed by the triangle shown above is 1 kg. Let x be the moment of inertia of the area enclosed by all three circles (intersection, *not* union) about the axis perpendicular to the page and through the center of mass of the triangle. Then, x can be expressed as $\frac{a\pi - b\sqrt{c}}{d\sqrt{e}}$ kg m², where a, b, c, d, e are integers such that $\gcd(a, b, d) = 1$ and both c and e are squarefree. Compute $a + b + c + d + e$.

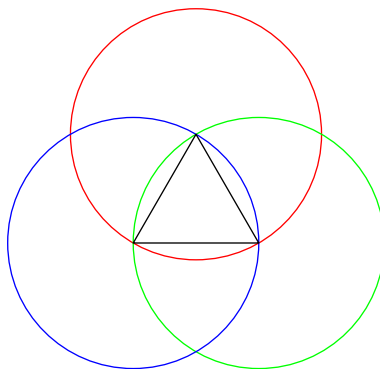
**Pr 34. Global Warming**

Life on Earth would not exist as we know it without the atmosphere. There are many reasons for this, but one of which is temperature. Let's explore how the atmosphere affects the temperature on Earth. Assume that all thermal energy striking the earth uniformly and ideally distributes itself across the Earth's surface.

- Assume that the Earth is a perfect black body with no atmospheric effects. Let the equilibrium temperature of Earth be T_0 . (The sun outputs around 3.846×10^{26} W, and is 1.496×10^8 km away.)
- Now assume the Earth's atmosphere is isothermal. The short wavelengths from the sun are nearly unaffected and pass straight through the atmosphere. However, they mostly convert into heat when they strike the ground. This generates longer wavelengths that do interact with the atmosphere. Assume that the albedo of the ground is 0.3 and e , the emissivity and absorptivity of the atmosphere, is 0.8. Let the equilibrium average temperature of the planet now be T_1 .

What is the percentage increase from T_0 to T_1 ?

Note: The emissivity is the degree to which an object can emit longer wavelengths (infrared) and the absorptivity is the degree to which an object can absorb energy. Specifically, the emissivity is the ratio between the energy emitted by an object and the energy emitted by a perfect black body at the same temperature. On the other hand, the absorptivity is the ratio of the amount of energy absorbed to the amount of incident energy.

Pr 35. Power Dissipation

THIS QUESTION HAS BEEN REMOVED FROM THE EXAM.

Pr 36. Flattening the Curve

Two infinitely long current carrying wires carry constant current $i_1 = 2$ A and $i_2 = 3$ A as shown in the diagram. The equations of the wire curvatures are $y^2 - 8x - 6y + 25 = 0$ and $x = 0$. Find the magnitude of force (in Newtons) acting on one of the wires due to the other.

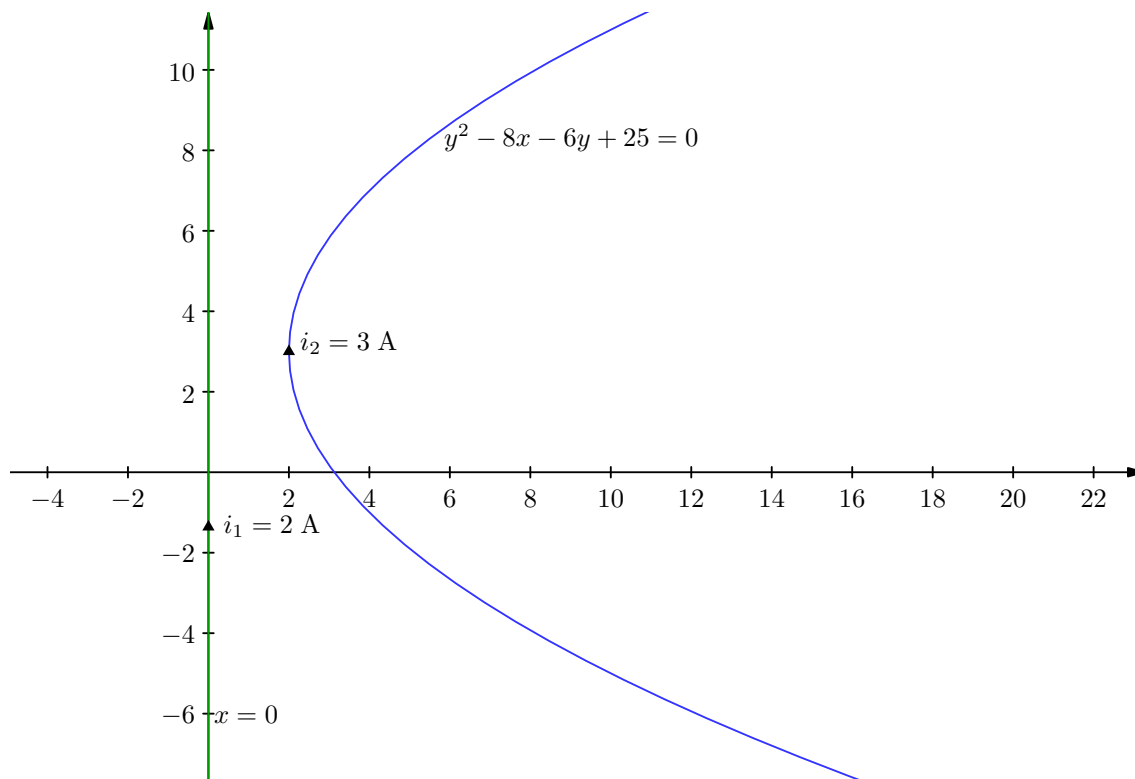

Note: The current-carrying wires are rigidly fixed. The units for distances on the graph should be taken in metres.

Pr 37. Hiking in Mountains

Mountains have two sides: windward and leeward. The windward side faces the wind and typically receives warm, moist air, often from an ocean. As wind hits a mountain, it is forced upward and begins to move towards the leeward side. During social distancing, Rishab decides to cross a mountain from the windward side to the leeward side of the mountain. What he finds is that the air around him has warmed when he is on the leeward side of the mountain.

Let us investigate this effect. Consider the warm, moist air mass colliding with the mountain and moving upwards on the mountain. Disregard heat exchange with the air mass and the mountain. Let the humidity of the air on the windward side correspond to a partial vapor pressure 0.5 kPa at 100.2 kPa and have a molar mass of $\mu_a = 28$ g/mole. The air predominantly consists of diatomic molecules of oxygen and nitrogen. Assume the mountain to be very high which means that at the very top of the mountain, all of the moisture in the air condenses and falls as precipitation. Let the precipitation have a heat of vaporization $L = 2.4 \cdot 10^6$ J/kg and molar mass $\mu_p = 18.01$ g/mole. Calculate the total change in temperature from the windward side to the leeward side in degrees Celsius.

Pr 38. Me and my Crush

Two electrons are in a uniform electric field $\mathbf{E} = E_0 \hat{\mathbf{z}}$ where $E_0 = 10^{-11}$ N/C. One electron is at the origin, and another is 10 m above the first electron. The electron at the origin is moving at $u = 10$ m/s at an angle of 30° from the line connecting the electrons at $t = 0$, while the other electron is at rest at $t = 0$. Find the minimum distance between the electrons. You may neglect relativistic effects.

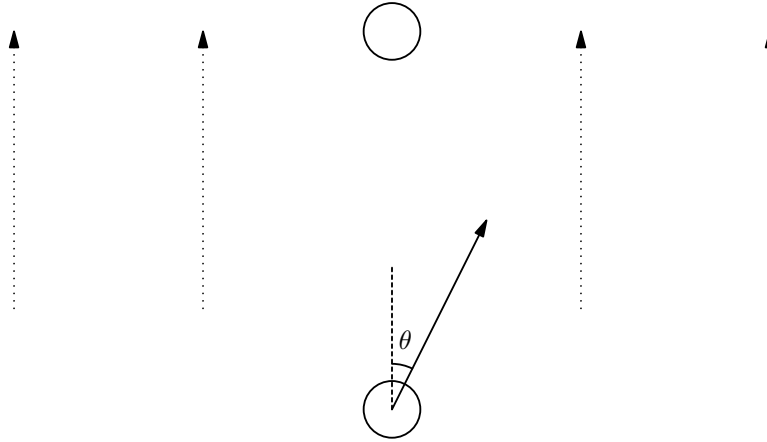

Pr 39. Can't or can

Consider a long uniform conducting cylinder. First, we divide the cylinder into thirds and remove the middle third. Then, we perform the same steps on the remaining two cylinders. Again, we perform the same steps on the remaining four cylinders and continuing until there are 2048 cylinders.

We then connect the terminals of the cylinder to a battery and measure the effective capacitance to be C_1 . If we continue to remove cylinders, the capacitance will reach an asymptotic value of C_0 . What is C_1/C_0 ?

You may assume each cylindrical disk to be wide enough to be considered as an infinite plate, such that the radius R of the cylinders is much larger than the d between any successive cylinders.



Note: The diagram is not to scale.

Pr 40. Mom Trust the Physics!

A square based pyramid (that is symmetrical) is standing on top of a cube with side length $\ell = 10$ cm such that their square faces perfectly line up. The cube is initially standing still on flat ground and both objects have the same uniform density. The coefficient of friction between every surface is the same value of $\mu = 0.3$. The cube is then given an initial speed v in some direction parallel to the floor. What is the maximum possible value of v such that the base of the pyramid will always remain parallel to the top of the cube? Answer in meters per second.

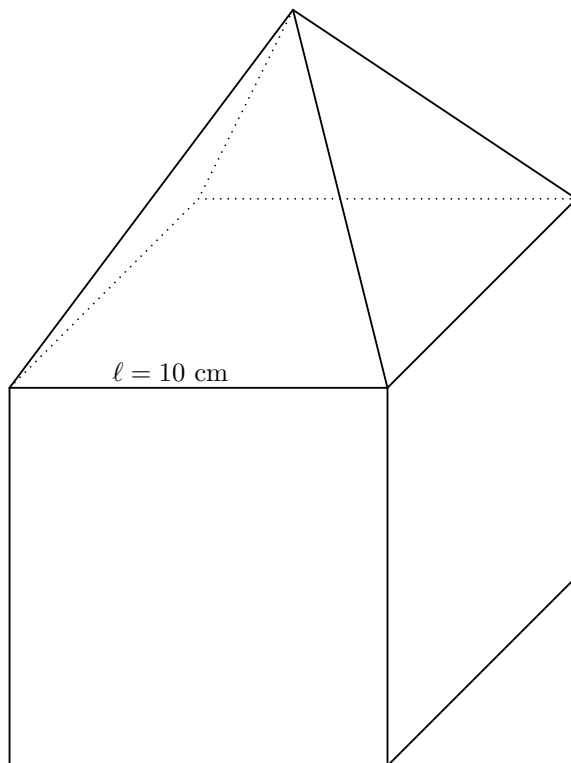

Pr 41. FBI Open Up!

During quarantine, the FBI has been monitoring a young physicist's suspicious activities. After compiling weeks worth of evidence, the FBI finally has had enough and searches his room.

The room's door is opened with a high angular velocity about its hinge. Over a very short period of time, its angular velocity increases to $\omega = 8.56$ rad/s due to the force applied at the end opposite from the hinge. For simplicity, treat the door as a uniform thin rod of length $L = 1.00$ m and mass $M = 9.50$ kg. The hinge (pivot) is located at one end of the rod. Ignore gravity. At what distance from the hinge of the door is the door most likely to break? Assume that the door will break at where the bending moment is largest. (Answer in metres.)

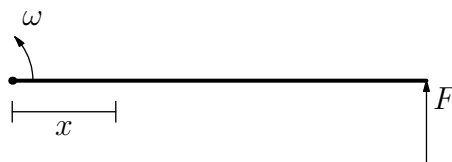

Pr 42. Pappu's Half Disk

A solid half-disc of mass $m = 1$ kg in the shape of a semi-circle of radius $R = 1$ m is kept at rest on a smooth horizontal table. QiLin starts applying a constant force of magnitude $F = 10$ N at point A as shown, parallel to its straight edge. What is the initial linear acceleration of point B? (Answer in m/s^2)

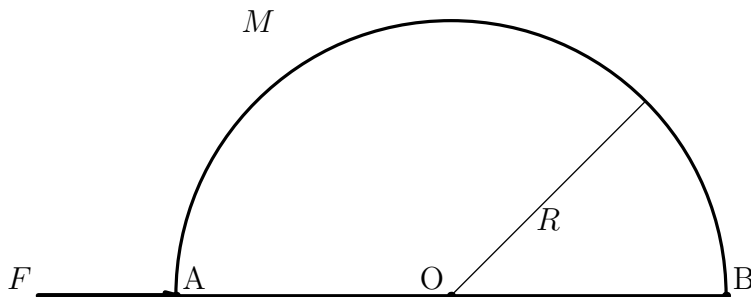

Note: the diagram above is a *top down view*.

Pr 43. Don't Fall

A regular tetrahedron of mass $m = 1$ g and unknown side length is balancing on top of a hemisphere of mass $M = 100$ kg and radius $R = 100$ m. The hemisphere is placed on a flat surface such that it is at its lowest potential. For a certain value of the length of the regular tetrahedron, the oscillations become unstable. What is this side length of the tetrahedron?

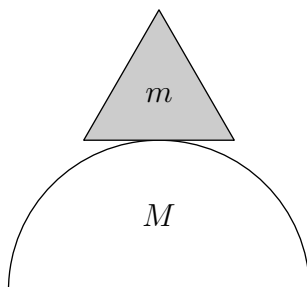
**Pr 44. Heartbreak**

A planet has a radius of 10 km and a uniform density of 5 g/cm^3 . A powerful bomb detonates at the center of the planet, releasing 8.93×10^{17} J of energy, causing the planet to separate into three large sections each with equal masses. You may model each section as a perfect sphere of radius r' . The initial and final distances between the centers of any two given sections is $2r'$. How long does it take for the three sections to collide again?

Pr 45. Hot or Not

THIS QUESTION HAS BEEN REMOVED FROM THE EXAM.

Pr 46. Sandwiched!

A point charge $+q$ is placed a distance a away from an infinitely large conducting plate. The force of the electrostatic interaction is F_0 . Then, an identical conducting plate is placed a distance $3a$ from the charge, parallel to the first one such that the charge is "sandwiched in." The new electrostatic force the particle feels is F' . What is F'/F_0 ? Round to the nearest hundredths.

The following information applies to the next three problems. Jerry spots a truckload of his favourite golden yellow Swiss cheese being transported on a cart moving at a constant velocity $v_0 = 5 \text{ m/s } \hat{i}$ along the x-axis,

which is initially placed at $(0, 0)$. Jerry, driven by desire immediately starts pursuing the cheese-truck in such a way that his velocity vector always points towards the cheese-truck; however, Jerry is smart and knows that he must maintain a constant distance $\ell = 10$ m from the truck to avoid being caught by anyone, no matter what. Note that Jerry starts at coordinates $(0, \ell)$.

Pr 47. Tom and Jerry 1

Let the magnitude of velocity (in m/s) and acceleration (in m/s^2) of Jerry at the moment when the (acute) angle between the two velocity vectors is $\theta = 60^\circ$ be α and β respectively. Compute $\alpha^2 + \beta^2$.

Pr 48. Tom and Jerry 2

At a certain instant during Jerry's motion, when his distance from the x-axis is 2 m, let his distance from the y-axis be ξ (in metres), and let his speed at $t = 1$ second be ψ m/s. Compute $\xi^2 + \psi^2$.

Pr 49. Tom and Jerry 3

Tom spots Jerry's footprints in the mud after Jerry has already travelled a distance $\ell = 10$ m towards the cheese truck. He starts moving at a constant speed of 5 m/s (except for a very large acceleration at the start, a result of his dislike for Jerry) along Jerry's trail. Alas, as is destined, he will never be able to catch Jerry. After a long period of time, what will be the separation between them? (in meters) Assume that Tom and Jerry have the energy to maintain their velocities for a very long period of time. Tom starts chasing Jerry from the same place Jerry started running towards the cheese truck.

Pr 50. Ghoster Coaster

A frictionless track contains a loop of radius $R = 0.5$ m. Situated on top of the track lies a small ball of mass $m = 2$ kg at a height h . It is then dropped and collides with another ball of mass $M = 5$ kg.

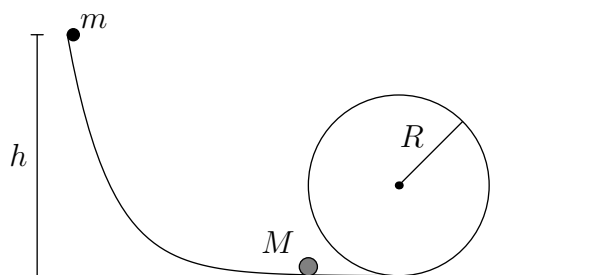

The coefficient of restitution for this collision is given as $e = \frac{1}{2}$. Now consider a different alternative. Now let the circular loop have a uniform coefficient of friction $\mu = 0.6$, while the rest of the path is still frictionless. Assume that the balls can once again collide with a restitution coefficient of $e = \frac{1}{2}$. Considering the balls to be point masses, find the minimum h such that the ball of mass M would be able to move all the way around the loop. Both balls can be considered as point masses.

Pr 51. Galactic Games

Two astronauts, Alice and Bob, are standing inside their cylindrical spaceship, which is rotating at an angular velocity ω clockwise around its axis in order to simulate the gravitational acceleration g on earth. The radius of the spaceship is R . For this problem, we will only consider motion in the plane perpendicular to the axis of the spaceship. Let point O be the center of the spaceship. Initially, an ideal zero-length spring has one end fixed at point O , while the other end is connected to a mass m at the “ground” of the spaceship, where the astronauts are standing (we will call this point A). From the astronauts’ point of view, the mass remains motionless.

Next, Alice fixes one end of the spring at point A , and attaches the mass to the other end at point O . Bob starts at point A , and moves an angle θ counterclockwise to point B (such that AOB is an isosceles triangle). At time $t = 0$, the mass at point O is released. Given that the mass comes close enough for Bob to catch it, find the value of θ to the nearest tenth of a degree.

Assume that the only force acting on the mass is the spring’s tension, and that the astronauts’ heights are much less than R .

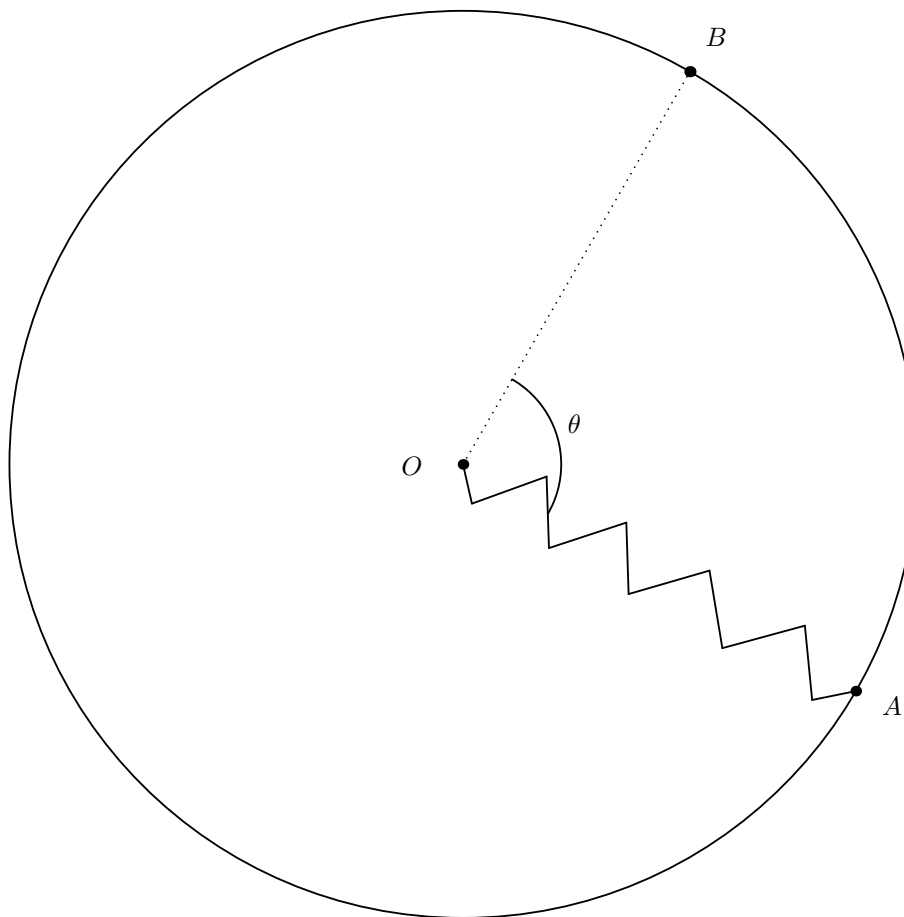

Pr 52. Cramped Up

Consider an LC circuit with one inductor and one capacitor. The amplitude of the charge on the plates of the capacitor is $Q = 10$ C and the two plates are initially at a distance $d = 1$ cm away from each other. The plates are then slowly pushed together to a distance 0.5 cm from each other. Find the resultant amplitude of charge on the parallel plates of the capacitor after this process is completed. Note that the initial current in the circuit is zero and assume that the plates are grounded.

Pr 53. I knew I should've stayed home today

A bicycle wheel of mass $M = 2.8$ kg and radius $R = 0.3$ m is spinning with angular velocity $\omega = 5$ rad/s around its axis in outer space, and its center is motionless. Assume that it has all of its mass uniformly concentrated on the rim. A long, massless axle is attached to its center, extending out along its axis. A ball of mass $m = 1.0$ kg moves at velocity $v = 2$ m/s parallel to the plane of the wheel and hits the axle at a distance $h = 0.5$ m from the center of the wheel. Assume that the collision is elastic and instantaneous, and that the ball's trajectory (before and after the collision) lies on a straight line.

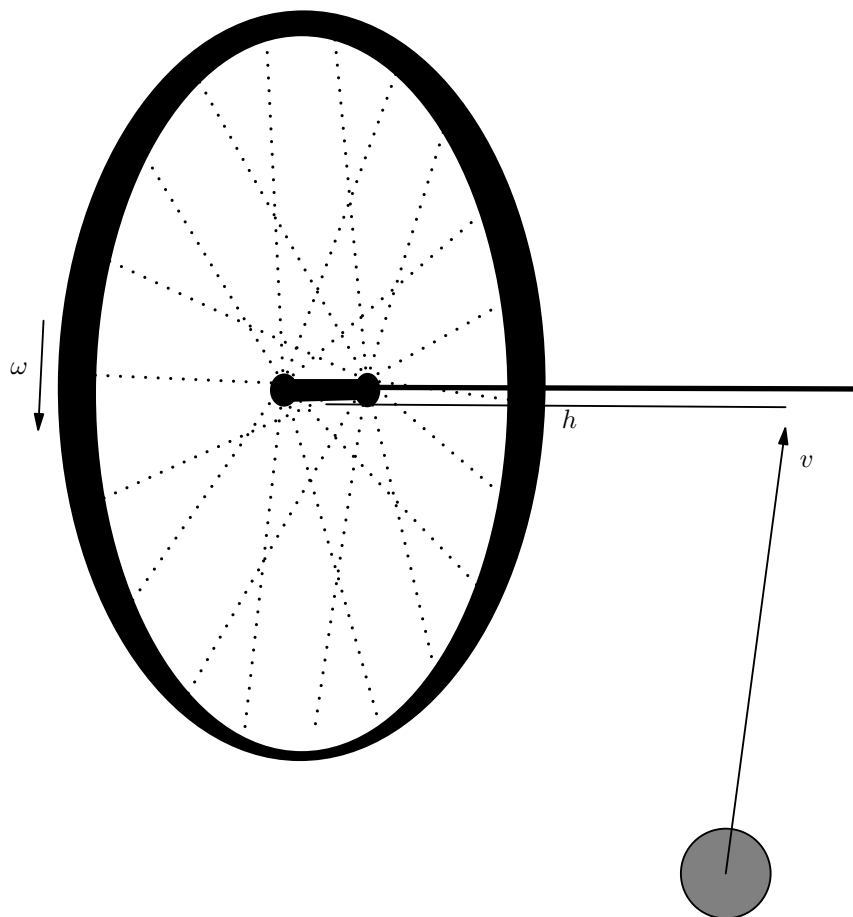

Find the time it takes for the axle to return to its original orientation. Answer in seconds and round to three significant figures.

Pr 54. Fun with a String

A child attaches a small rock of mass $M = 0.800$ kg to one end of a uniform elastic string of mass $m = 0.100$ kg and natural length $L = 0.650$ m. He grabs the other end and swings the rock in uniform circular motion around his hand, with angular velocity $\omega = 6.30$ rad/s. Assume his hand is stationary, and that the elastic string behaves like a spring with spring constant $k = 40.0$ N/m. After that, at time $t = 0$, a small longitudinal perturbation starts from the child's hand, traveling towards the rock. At time $t = T_0$, the perturbation reaches the rock. How far was the perturbation from the child's hand at time $t = \frac{T_0}{2}$? Ignore gravity.

Pr 55. When Rocket Scientists Play Catch

During the cold war, there was tension between the USSR and the U.S. But now, contrary to popular belief, American and Russian astronauts pass time by hanging out, enjoying the view from the moon, and even playing catch by launching projectiles at each other:

A projectile is launched with a speed $v_0 = 2200$ m/s from the North Pole to the South Pole of a moon with radius $r_0 = 1.7 \times 10^6$ m and $M = 7.4 \times 10^{22}$ kg.

How long does the flight take? Answer in seconds.

